

## References

### Bridge construction



Issue 09/2023

**PERI SE**  
**Formwork Scaffolding Engineering**

Rudolf-Diesel-Strasse 19  
 89264 Weissenhorn  
 Germany  
 info@peri.com  
 www.peri.com



**Important Notes**

Without exception, all current safety regulations must be observed in those countries where our products are used.

The photos shown in this brochure feature construction sites in progress. For this reason especially safety and anchor details cannot always be considered as conclusive or final. These are subject to the risk assessment carried out by the contractor.

The systems or items shown are not necessarily available in all countries.

Safety instructions and load specifications are to be strictly observed at all times. Separate structural calculations are required for any deviations from the standard design data.

The information contained herein is subject to technical changes in the interests of progress.

## The Mulde Bridge in Schlunzig, Zwickau

A combined formwork and scaffolding solution for sophisticated bridge pylons



**The new 100-metre-long cable-stayed bridge will replace the previous bridge over the river Mulde. The old bridge was badly damaged during flooding back in 2013 and, in the aftermath, could only be used to a limited extent. A variant analysis determined that construction of a new, two-section, cable-stayed bridge would be the most cost-effective solution. The spans of the new 15-metre-wide bridge are 35.50 m and 55.50 m.**

A distinctive 34-metre-high pylon supports the roadway slab which is suspended from 24 HDPE-encased stay cables. The demanding and unusual bridge project has posed significant challenges to the parties involved. The two pylon uprights that extend up to a height of almost 23 m where they meet up with a cross beam are inclined by 7.3 degrees from the vertical. The full cross-sections, which measure 2.20 m x 1.50 m at the base, are gradually tapered down to 1.60 m x 1.50 m as they stretch upwards. With the aid of the PERI concept, the bridge pylon was built in four stages, each with a standard cycle height of 5.15 m up to the change in inclination. This was

followed by a 2.60-metre-high pier section, which was built at the same time as the 1.50-metre-thick and 11.25-metre-long cross beam. In the sixth and final stage of the construction process, the two 10-metre-high vertical pylon heads were formed. Steel mounting components, each weighing 21 t, were also installed at this stage. These components had to be incorporated into the formwork solution.

The formwork and scaffolding concept was based on the VARIO GT 24 girder formwork, combined with PERI UP shoring that was erected gradually in line with the formwork and scaffolding. The support and working platforms were configured using systematic steel walers from the VARIOKIT Engineering Construction Kit and GT 24 formwork girders. A PERI UP stair tower, which was linked to the load-bearing system, provided safe and convenient access to the individual levels. PERI pre-fabricated the formwork elements for the initial formwork, the pier formwork and for forming the cross beam with the utmost precision and delivered them to the construction site ready for installation. In addition to the factory-based formwork assembly process, an exten-

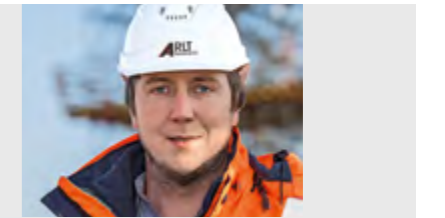

**Paul Hopperditzel**  
Site Manager

“The cable-stayed bridge over the Mulde river is a demanding construction project and one that has posed challenges to everyone involved. The quality of the PERI formwork solution is top-notch and we have even managed to get ahead of schedule.”

sive service package also facilitated swift execution of the construction work. The decision to act early in coordinating the joint and tie arrangement for the pylon, which was to be constructed using architectural concrete class AC 2, was another important aspect of the PERI planning process.

**Contractor**  
Arlt GmbH, Frohburg  
**Project coordination**  
PERI NL Leipzig; Infrastructure  
Competence Center,  
Weißenhorn/Cottbus

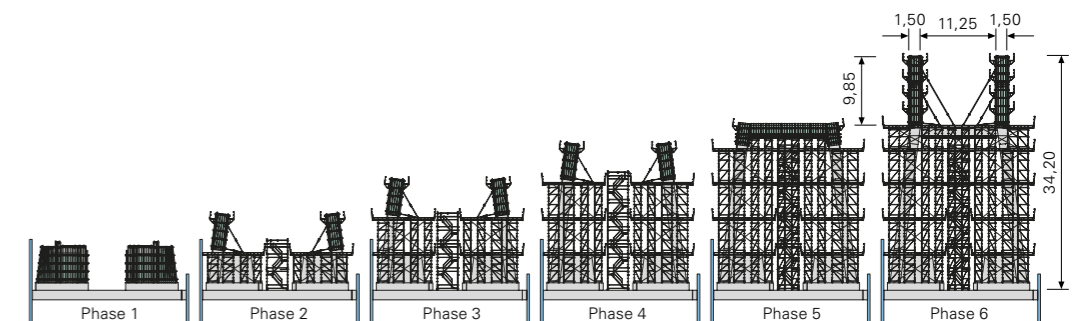

## Historical railway bridge, Lautrach/Illerbeuren

Mobile and height-adjustable: Cost-effective bridge renovation with the VARIOKIT suspended scaffold



**Paul Haggemüller**  
Foreman

"I am absolutely delighted with the PERI scaffold carriage. Everything is going better than expected."



**Contractor**  
Xaver Lutzenberger GmbH & Co. KG,  
Pfaffenhausen  
**Project coordination**  
PERI Weißenhorn

**The historical Illerbrücke is a bridge between Illerbeuren and Lautrach that has been declared a historic monument. The 90-metre-long arch bridge was built in 1903 using the tamped concrete method, i.e. without steel reinforcement. The former railway bridge has been used as a footpath and cycle path since 1975.**

Renovation work needed to be carried out after penetrating water caused damage to the bridge. As part of the first construction phase in 2017, the superstructure was partially renovated by installing a new, waterproofing concrete slab and additional parapets and refurbishing the bridge railings. The bridge arch, piers and foreland arches are now being repaired as part of the second phase. The different work steps are being performed section by section with the aid of a mobile

VARIOKIT suspended scaffold: Chipping, water-jet cutting, application of sprayed concrete, sandblasting and sheet metal work. The 5 platforms that are suspended on both the left and right sides serve as working levels for renovating the outside of the bridge and as access to the entire height of the bridge. An integrated, height-adjustable intermediate platform that can be safely guided on the suspended scaffold using RCS climbing shoes provides access to the underside of the bridge.



## New Champlain Bridge, Montreal, Canada

ACS and RCS: the right team for cycle sequences



**The new Champlain Bridge was designed to replace the old structure and allow around 50 million vehicles per year to cross the St. Lawrence River. During the construction of the 170 m high pylons, PERI ACS and RCS facilitated a 12-day concreting cycle.**

The new Champlain Bridge is a 3.4 km long cable-stayed bridge with a striking, approx. 170-m-high concrete pylon and asymmetrically arranged guy ropes. The characteristic bridge between Montreal and Brossard includes a two-lane railway corridor, six lanes for vehicles and a pathway for both cyclists and pedestrians. PERI provided a complete climbing solution for the upper pylon as well as extensive on-site support.

The RCS Rail Climbing System was used on the inside of the hollow pylon legs, while the ACS Self-Climbing System raised the VARIO formwork on the outside. The combination of the climbing systems supported the fast construction progress: both systems could



**Isabelle Genest**  
Project Manager Pylons

"I'm extremely satisfied with the climbing solution and cooperation with PERI. I would recommend their systems to anyone. Simple application and short execution time really helped us realise this project."

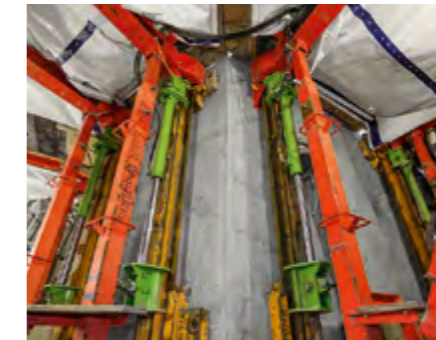

be lifted into the next section using climbing hydraulics, crane time could be reduced and the 6 m high sections climbed in 12-day cycles. The working platforms remained securely attached to the pylons during the entire climbing process and provided construction site personnel with a comfortable and safe working environment at all times.

On the outer side of the ACS system, RCS system protection panel enclosures – pre-assembled on the ground – formed a virtually gap-free protective shield for the working platforms. As a result, this further increased safety

levels and protected the workers against the sometimes harsh weather conditions high above the St. Lawrence River.

At the PERI assembly hall, climbing platforms and VARIO Girder Wall Formwork elements were accurately adapted to match the complex pylon geometry and delivered to the construction site as pre-assembled units. The final assembly took place here in accordance with the detailed PERI general arrangement drawings under the guidance of an experienced PERI supervisor.

**Contractor**

SIGNATURE SUR LE SAINT-LAURENT CONSTRUCTION: SNC-Lavalin, ACS, HOCHTIEF; Melbourne, Canada

**Field Service**

PERI Canada, Laval and Bolton PERI Group, Weisenhorn, Germany

## Las Truchas Highway Bridge, Nayarit, Mexico

Simple solution in a particularly challenging terrain



**In a difficult-to-access and densely forested area, PERI ALPHAKIT was able to utilise its strengths to the full. The lightweight system components facilitated the time and space-saving execution of the four-lane highway bridge near Las Truchas.**

The ambitious infrastructure project, in the southwest region of the Mexican state of Nayarit, extends the road network between the mega city of Guadalajara and the Gulf of California. Among other things, it was necessary to build a 433 m long bridge in an area crisscrossed by mountains and valleys. PERI planned and supplied the formwork and shoring solution for cost-effective

construction of the four-lane structure, despite the demanding logistics due to the rough terrain.

VARIO Girder Wall Formwork on CB Climbing Formwork was used to realise the total of four piers up to 48 m high. This proven combination facilitated a cost-effective execution of the bridge piers in 4.80 m high concreting sections. After reaching the planned pier heights, horizontally positioned SB Brace Frames supported construction of the pier heads.

For the edge areas of the bridge, PERI engineers and the contractors developed an efficient solution based on the ALPHAKIT System. For this, the

materials were delivered just-in-time to the jobsite to meet the respective construction phase requirements and mounted on-site to form ALPHAKIT Heavy-Duty Truss Girders and shoring towers. As a result, the 65 m long construction for the superstructure build, consisting of heavy-duty truss girder units, could be realised with a minimum of space and crane time. The outermost 12 m of the central bridge section was supported by ST 100 Stacking Towers. This solution made it possible to realise an 80 m superstructure section in one piece. After concreting and striking, this section was simply moved into a new position on the opposite side of the bridge.



**Carlos Piernas**  
Project Superintendent

"I've known PERI for 35 years now, from my time in Spain. Exactly like there, the materials here in Mexico are in very good condition. The technical department did a fantastic job. ALPHAKIT, just like the other PERI systems, is an excellent system that allows us to work much faster and easier."

**Contractor**  
Azvi Mexico, Ciudad de México Grupo Azvi, Sevilla, Spain  
**Field Service**  
PERI Mexico, Huehuetoca

## Fjordforbindelsen Bridge, Frederikssund, Denmark

Well-thought-out climbing formwork solution for V-shaped piers



**Pablo Fernandez Rodero**  
Site Manager

“We decided in favour of PERI due to the guaranteed quality and safety considerations along with a convincing price-performance ratio. An essential part of the excellent cooperation was the technical support right from the very start of construction.”

**Contractor**

RBAI JV I/S: Rizzani de Eccher, Udine, Italy;  
Acciona Infraestructuras, Aclobendas, Spain;  
BESIX, Brussels, Belgium

**Field Service**

PERI Denmark, Greve

**PERI system solutions and engineering services ensured high quality and safe working conditions for the construction of the important road link across the Roskilde Fjord.**

The 1,400 m long, four-lane bridge, spanning the Roskilde Fjord between Marbæk and Tørslev, shortens the connection between two peninsulas south of Frederikssund. The 10 km long, four-lane expansion highway connection shortens travel times and takes the high volume of through-traffic away from the nearby inner city districts.

The 17 V-shaped bridge piers reach heights of up to 22 m. PERI planned and supplied the pier formwork for their construction. Form-giving VARIO GT 24 Girder Wall Formwork together with the SCS Climbing System created generously-sized climbing units that could be moved with only a few crane picks.

The low weight SCS is characterised in particular by its high load-bearing capacity. As a result, the number of anchor points is also reduced – which ensures an extremely high level of cost-effectiveness.

Access technology based on the PERI UP Scaffolding System ensured quick and reliable access to the respective working levels which, in turn, accelerated the overall construction progress. In order to form the foundations and abutments economically, the MAXIMO and TRIO Wall Formwork Systems were the ideal supplement to the PERI solution.



## M8 Road Bridge, Neustettin Bypass, Poland

Large spans realised within the system



**Krzysztof Kolosa**  
Project Manager Bridge Construction Technology

“The solution developed with PERI engineers using VRB truss girder units allowed us to work efficiently at all times in spite of the difficult ground conditions. Due to the delivery reliability of the required formwork and scaffolding materials, we were able to maintain the tight construction schedule. On-site training and constant construction supervision provided by the PERI supervisors ensured the correct assembly and maintenance of the materials.”

**Contractor**  
Eurovia Polska S.A.,  
Neustettin, Poland  
**Field Service**  
PERI Poland, Plochocin

**For the challenging 160 m long bridge construction in the wetlands area near the town of Neustettin, PERI engineers planned a formwork and scaffolding solution based on the VARIOKIT Engineering Construction Kit.**

As part of the S-11 motorway expansion project, the M-8 road bridge crosses the wetlands area surrounding the the Wilczy Canal with two lanes in both directions. Difficult ground conditions required a non-standard construction method that could not be realised using conventional support due to the large spans and high loads. PERI provided a very efficient solution to meet these requirements based on the VARIOKIT Engineering Construction Kit, which included planning, pre-assembly and delivery, as well as on-going project support.

The implementation plan envisaged two independent bridge superstructures with a pre-stressed, twin-webbed T-beam cross-section. The best solution proved to be a shoring construction with large span widths of 20.50 m and 25.50 m respectively, positioned on the foundations of the fixed bridge supports and without any intermediate supports in the bridge segments.

Planners combined VARIOKIT formwork units with components taken from the VARIO 24 Girder Wall Formwork system to form the superstructure consisting of bridge beams and the adjacent carriage-way slab. The respective sections of the two parallel superstructures were alternately concreted, whereby formwork and shoring were placed in an offset position from one bridge segment to the other.

PERI ensured timely pre-assembly of the 12.50 m long Heavy-Duty Truss Girder VRB segments at the PERI plant. Subsequently, several material packages – consisting of braced birdcage scaffolding with truss girder frames – were delivered just-in-time to the construction site, where they were connected to form girder pairs and mounted on the VST Shoring Tower Frames. In this way, the truss girders could be assembled at the same time as the shoring towers were erected.

PERI engineers supported the contractor's team throughout the entire construction process with punctual logistics and on-going project support. This meant that all requirements were met and the tight construction schedule was maintained.



## New Pumarejo Bridge, Barranquilla/Atlántico, Colombia

Record-breaking bridge successfully completed



**Juan Pablo Durán Project Manager**  
**Jorge Enrique Restrepo Sulez Site Manager**

“We are absolutely satisfied with our decision to work together with PERI. We were excellently supported throughout the project, and the simple handling of the systems also ensured increased work productivity.”

**For Colombia’s record-breaking bridge, the pylons, piers and superstructure had to be realised simultaneously. To this end, PERI provided a complete package consisting of a formwork and scaffolding solution adapted specifically for the project, as well as on-going jobsite support.**

The new cable-stayed bridge over the Rio Magdalena is the longest bridge in Colombia with a total length of 2.3 km. The main span is 380 m long. Here, the 38 m wide superstructure is supported by 80 m high pylons. Headroom up to 35 m allows ships to continue using the river; larger vessels can also be accommodated.

PERI engineers supported the challenging construction project with a tailored formwork and scaffolding solution, which was designed to facilitate simultaneous construction of the pylons, bridge piers and superstructure.

CB Climbing Platforms, together with TRIO Wall Formwork, formed crane-climbed moving units to form bridge piers up to 35 m high, as well as the two pylons. Due to the large scale, crane operations were kept to an absolute minimum for the 5 m high concreting cycles. In the area of pier heads, VARIOKIT framework units

served as a reliable support construction and working platform.

With the help of a geometrically adapted superstructure formwork based on the VARIOKIT Engineering Construction Kit, the bridge superstructure – designed in the form of a hollow box cross-section – was also realised. Perfectly matched PERI UP Flex and ST 100 formed load-bearing support constructions in the bridge perimeter areas with heights ranging from 5 m to 22 m. In addition, PERI UP was used to provide stair access, allowing site personnel to reach the higher working levels safely.



**Bauunternehmen**  
SES Puente Magdalena consortium:  
Sacyr Construcción Colombia SAS; Sacyr Chile;  
Esgamo Ingenieros Constructores  
**Projektbetreuung**  
PERI Kolumbien, Bogotá

## Mersey Gateway, Great Britain

ACS for pylons reaching dizzying heights



The new six lane, more than 2,000 m long Mersey Gateway Bridge with its three striking 125 m, 80 m and 110 m high pylons, provides considerable relief for the heavy flow of traffic in the Liverpool region, especially between Runcorn and Widnes.

**ACS Self-Climbing Formwork greatly accelerated the construction of the three, up to 125 m high pylons. In the process, the climbing hydraulics safely lifted the formwork and working platforms as one unit from section to section without requiring a crane and regardless of the weather.**

Three pylons carry the around 1,000 m long bridge superstructure across the River Mersey. For supporting the superstructure, the highest pylon widens at a height of approx. 20 m from 6 m to a total of 17.5 m. At this point, hammer-head and pier-head formwork were used.

For this, PERI's British engineers developed a concept on the basis of horizontally-positioned SB Brace Frame units that could be coupled together, whereby 7 m wide working levels were created. At the same time, the brace frames were used for transferring loads from the cantilevered concreting sections into the pylon shaft. The respective concreting heights were exactly matched to suit the anchoring possibilities in the shaft section previously concreted while forming took place requiring around 21 concreting cycles each 5 m high.

The ACS R Self-Climbing System, combined with VARIO GT 24 girder wall formwork, optimised the construction

of the upper pylon shaft. The wall formwork was suspended from the top working platform so that the formwork carriage could easily be retracted together with the formwork after striking and the top working platform could then be folded upwards. In this way, generous working areas for the reinforcement work were created. PERI UP Flex reinforcement scaffolding and all required materials were easily lifted in by crane.

The simultaneous climbing of several units reduced the number of leading edges. Furthermore, the enclosed working platforms provided additional safety and, at the same time, protection against the high wind speeds as well as rain.

### Contractor

Merseylink Civil Contractors: FCC Construcción S.A., Kier Infrastructure and Overseas Limited; Samsung C&T Corporation

### Field Service

PERI United Kingdom, Rugby



**C H Lee**  
Technical Director

"The PERI ACS Self-Climbing System in connection with the retractable formwork and PERI UP scaffolding served as quick and easy formwork for the pylon construction and safe access throughout. This solution accelerated the concreting work and shortened the cycle times so that we could climb 5 m high sections every 5 days."

## Kičevo-Podvis Motorway Bridge, Northern Macedonia

VARIOKIT cantilevered construction for a problem-free workflow



**Contractor**  
GD Granit, Skopje, Northern Macedonia  
**Field Service**  
PERI Serbia, Simanovci



**PERI engineers developed a project-specific solution for Northern Macedonia's longest cantilever bridge. In spite of the challenging terrain, the tight construction schedule was comfortably maintained.**

The 381 m long motorway bridge is part of the Pan-European Transport Corridor VIII, an international transport axis between Albania and Bulgaria. In the mountainous south-west region of Northern Macedonia, a total of 14 viaducts were built to realise the first sections of the route. The length of around 10 km required excavating more than 4,000,000 m<sup>3</sup> of earth, as well as processing 150,000 m<sup>3</sup> of concrete and 15,000 t of reinforcement.

The biggest challenge faced on the four-lane highway section was the viaduct at Kilometer 9, which had to be

constructed using the balanced cantilever method. For the bridge piers and superstructure, PERI provided the most cost-effective formwork solution. In particular, the hydraulic solutions for adapting and aligning purposes, along with the independent moving procedure of the formwork carriage, shortened execution times. As a result, the construction team realised a regular 7-day concreting cycle.

Four VBC cantilever formwork carriages from the VARIOKIT Engineering Construction Kit supported the building of the radially arranged bridge superstructure with a span of 165 m. Thanks to these carriages, it was possible to ensure that the separately executed 12.55 m and 11.55 m wide carriageway slabs were completed within the tight project schedule. The superstructure height varied between 9.00 m at the

piers and up to 4.00 m in the centre of the bridge. The concreting cycles also varied in length from 3.30 m through to 5.00 m. In addition to the constantly changing superstructure cross-sections, the PERI solution also took into account the constant longitudinal inclination of 2.8 %, as well as the variable transverse inclinations of 1.5 % to 6.0 %.

During the realisation of the bridge piers, SCS Climbing Formwork, supplemented by CB Climbing Platforms and horizontally positioned SB Brace Frames combined with the TRIO and VARIO GT 24 Wall Formwork Systems, ensured fast construction progress of the structures. PERI UP Stair Tower assembly kept pace with the formworking operations and provided safe access to the various working areas.



**Goran Milanovic Project Manager**  
**Ivana Dimitrova Site Manager**

"Together with the team of PERI engineers with their fantastic expertise, we quickly defined the technical solutions for realising the bridge project. It was extremely important to us that on-site support was always available when VARIOKIT was used."

## Puente sobre la Bahía de Cádiz, Spain

### Competent engineering services



**The new cable-stayed bridge over the Bay of Cádiz connects Puerto Real on the Andalusian mainland with Cádiz which lies on a peninsula. The overall length of the bridge construction is 3.2 km, and the six-lane carriageway crosses the bay up to 69 m above the level of the water. For transferring the loads of the 540 m long main section, two impressive almost 190 m high pylons are used.**

The entire bridge project with all pylons, piers and superstructure featured a very wide range of construction phases. PERI's broad product range provided the benefit of simplifying and optimising the construction progress

as this meant dealing with only one formwork and scaffolding partner – but nevertheless ensuring the right system equipment was made available in each case.

For the two dominating pylons, PERI Spain engineers combined VARIO GT 24 girder wall formwork with the ACS self-climbing system. During the formwork planning, they had to take into consideration the geometrical changes that occurred from the base to the widened area where the hexagonal ground plan transformed into a trapezoidal cross-section. The uppermost third section in the area of the cable-stay connections is in turn realised as a hexagon

and octagon. The continuous cross-sectional changes with all-sided curvatures, required an accurate pre-fabrication of the VARIO customised elements in the PERI assembly hall.

For the construction of the widened area up to the total width of 47 m at the height of the carriageway, the most cost-effective solution, however, proved to be a special construction in form of a steel truss construction. This facilitated, on the one hand, the safe transfer of the high concreting loads into the base and, on the other, provided integrated working levels for optimal accessibility for forming, reinforcement work and concreting.



**Victor M. Jiménez Aguadero**  
Site Manager

“Together with the PERI engineers, we could define a formwork concept for this bridge project which is based on the experience gained from numerous successfully completed projects.”



Around half of the 3.2 km bridge construction extends over the Bay of Cádiz – with a 540 m span and 69 m clearance height for shipping between the two pylons.



With help of the PERI steel construction, the high concreting loads of the 47 m long pylon widening could be safely transferred into the base.

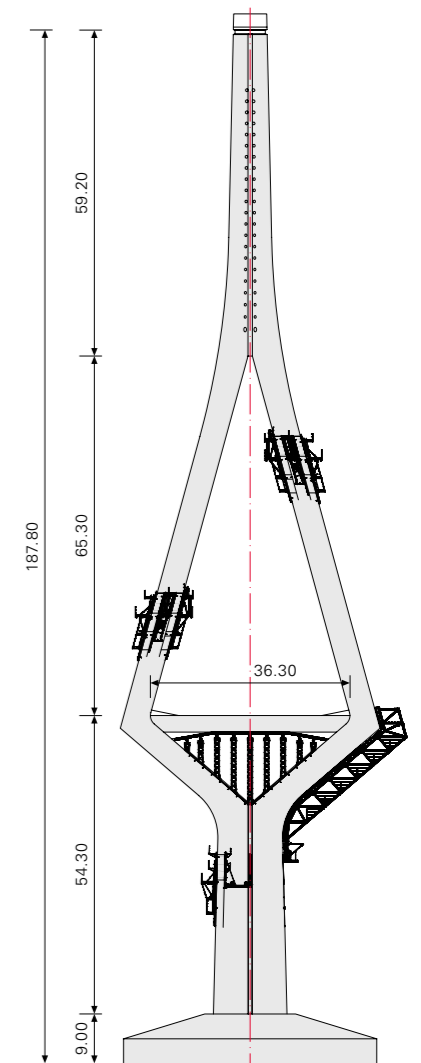

**Contractor**  
UTE Puente de Cádiz  
Dragados S.A., Madrid  
F.P.S. S.A., Madrid  
**Field Service**  
PERI Sevilla, Malaga and Madrid, Spain

The VARIO GT 24 girder wall formwork climbed on ACS R self-climbing brackets. Also for the working platforms and access technology, mostly rentable PERI standard systems was used.

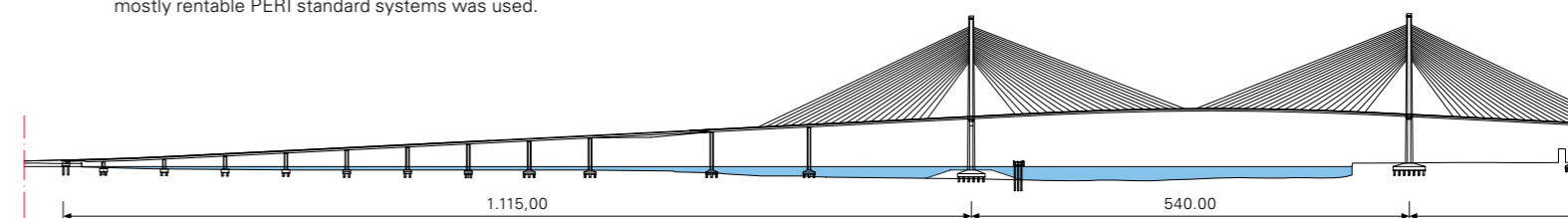

# Megyeri Danube Bridge, Budapest, Hungary

## Safe and reliable construction over the Danube

The new bridge construction near Budapest with two highly visible reinforced concrete pylons is part of the northern section of the M0 motorway. This connects the M3 motorway with the main artery road 11.



**Main Contractor**  
M0 North Danube-Bridge Consortium  
Hidépítő Zrt.  
STRABAG Zrt.  
**Field Service**  
PERI Budapest, Hungary and  
PERI Weissenhorn, Germany

The altogether 1.9 km long motorway bridge over the Danube rests on 28 piers in the foreland areas – central element is the 590 m long cable-stayed bridge over the major distributary with a 300 m span between the two impressive pylons. Up to the reinforced concrete tip at a height of 100 m, a total of 29 casting segments with variable concreting heights between 2.55 m and 4.07 m had to be mastered. The pylon supporting members are inclined towards to the centre of the roadway at an angle of under 13.3° and have a range of different cross-sections.

Beginning with external dimensions of 5.00 m x 4.11 m on the bottom plate, the members taper up to 3.50 m x 4.11 m in the area of the cable stay connections. The internal dimensions are also reduced in the longitudinal direction by 0.80 m. For the forward and reverse-inclined external walls, PERI ACS V was used as climbing scaffold.

Through the continuously adjustable brackets, the working platforms were always in a horizontal position which meant work could be carried out safely and ergonomically. For the remaining external wall surfaces, ACS R brackets were selected which proved their suitability once again on this construction site for laterally-inclined climbing.

Guardrails and weather-resistant sheeting were installed on the external scaffolding to totally enclose the five working levels, positioned one on top of each other. This resulted in optimal working safety conditions and provided ideal protection against the weather.



The five working levels provided safe and generously-sized working areas for personnel, tools and equipment.

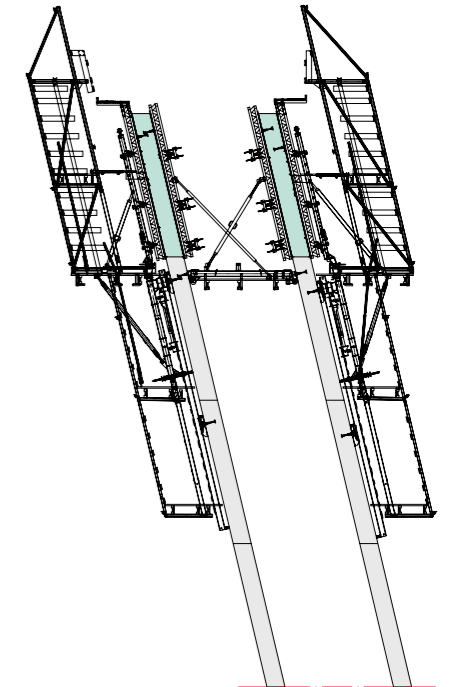

The adjustable ACS V self-climbing system was the ideal solution for the inclined pylon supporting members.



**Császár Csaba**  
Technical Director

“The safety and reliability of the PERI ACS self-climbing formwork is of particular importance in such a project. With help of the VARIO customised formwork, we could complete the varying cross-sections of the pylons on schedule and with great accuracy.”

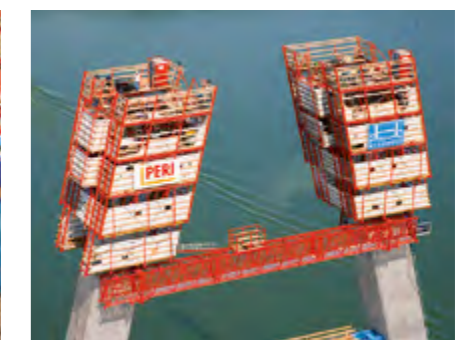

With the help of the central power supply unit, the eight hydraulic ACS climbing devices were able to climb in perfect synchronization.

Through the catwalk between the pylons, only one elevator was required which greatly reducing the amount of walking for site personnel. The catwalk was always positioned horizontally regardless of the angle of the climbing formwork units.

## Golden Ears Bridge, Vancouver, Canada

Four pylons formed in weekly cycles without a crane



The Golden Ears Bridge is a 970 m long cablestayed bridge over the Fraser River. It is the core element of the 13 km six-lane highway project near Vancouver which was completed and opened to traffic in June 2009 – in time for the 2010 Winter Olympic Games. The structure was designed as a so-called extradosed bridge, a cross between a girder bridge and a cable-stayed bridge. Here, the inclined cables function like a pre-stressed construction installed outside of the superstructure and are positioned at an extremely flat angle. In spite of the 242 m span, the pylon heights could be restricted to a maximum 86 m.



**Michael Hug**  
Site Foreman

“I’ve been working for many years with PERI systems and I am convinced that the ACS climbing system and the VARIO wall formwork is the optimal solution. With the ACS, we were able to shorten the construction time. In my opinion, PERI provides the technically best formwork systems.”

**Contractor**  
Bilfinger Berger Inc., Vancouver  
**Field Service**  
PERI Vancouver, Canada and  
PERI Weissenhorn, Germany

The formwork and scaffolding solution for the four H-shaped pylons was based on the modular-designed ACS self-climbing technology and the VARIO GT 24 girder wall formwork system. As a result, the continuously-changing pylon cross-sections could be constructed using 4-metre concreting cycle heights without requiring any crane support. Furthermore, the ACS climbing system was designed to handle extremely high wind loads due to the coastal location so that even during wind speeds of up to 80 km/h, safe climbing operations could be carried out. The pylon legs underneath the carriageway deck were to be constructed as double piers in a longitudinal direction, and as individual piers in the form of a composite construction with prefabricated steel cores for the upper half. Through the use of

two separate ACS/VARIO sets of formwork, one set for the top and bottom halves of the pylon respectively, time-consuming adjustment work on the climbing platforms and formwork could be avoided as well as keeping on-site material requirements to a minimum. For forming the front ends, the formwork elements were mounted on climbing platforms positioned on the longitudinal sides with the complete construction suspended on rollers – this meant that climbing brackets were not required at the front ends. Only two climbing units were needed per individual pier – this accelerated each climbing operation and reduced material requirements and the costs. Offset ACS brackets ensured that the platforms of the four different working levels could still be securely interlocked.

Project-compliant solutions for the approach bridges and elevations as well: PERI system brackets from the VARIOKIT engineering construction kit for concreting the carriageway slab.

Working platforms with a total length of 600 m ensured efficient construction progress and safe working conditions.

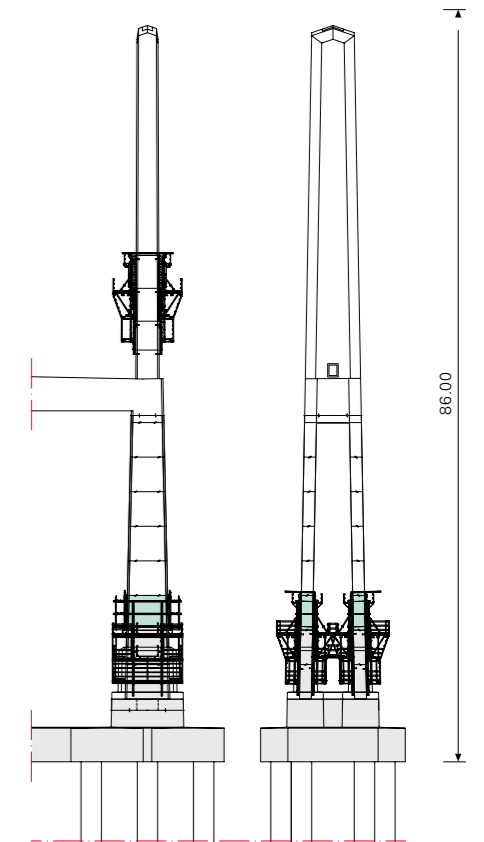

Climbing took place every Monday: initially, the pylon legs with around 4 m concreting cycle heights in eight climbing stages up to the level of the carriageway. After the cross-member had been concreted, eleven further climbing cycles followed.

## Motorway Bridge near Lamia, Greece

Two VARIOKIT composite formwork carriages using the back-step method



The A1 motorway connects the two cities of Athens and Thessaloniki and is considered to be the most important arterial road in Greece. For crossing the National Highway 3 and a railway line, an 840 m long steel composite bridge was constructed. The two separate, parallel superstructures both feature 22-field spans ranging between 27 m and 45 m.

Using the back-step construction method, the two VARIOKIT composite formwork carriages – each 25 m long and 14.50 m wide – ensured that

concreting could take place every second day. The field cycles with standard cycle lengths of up to 22.50 m, were constructed in advance and the second formwork carriage was used to form the areas of the piers. Reinforcement work was carried out in advance on two additional sets of slab formwork which were then subsequently attached to the formwork carriage for concreting operations.

In regular 2-day cycles, one section could be always concreted while the other carriage was moved to the next area by means of heavy duty rollers.

As all system components of the VARIOKIT engineering construction kit are standardised, and therefore rentable, hardly any special parts were required. This makes the PERI formwork carriage solution extremely cost-effective. Nevertheless, VARIOKIT was very flexible in its use because individual components were optimally matched to each other in order to suit the requirements of the construction site.

**Contractor**  
Terna S.A., Athen  
**Field Service**  
PERI Athens, Greece  
and PERI Weissenhorn, Germany



**Gerasimos Bougelis**  
Site Manager

“The decision to use the VARIOKIT formwork carriage was correct. Both carriages are very stable and all the system components are rentable. With this, shuttering and striking is simple and moving is also very easy – the planned construction period has been shortened by around 3 months.”

The 840 m long motorway bridge crosses a national highway and a railway line.

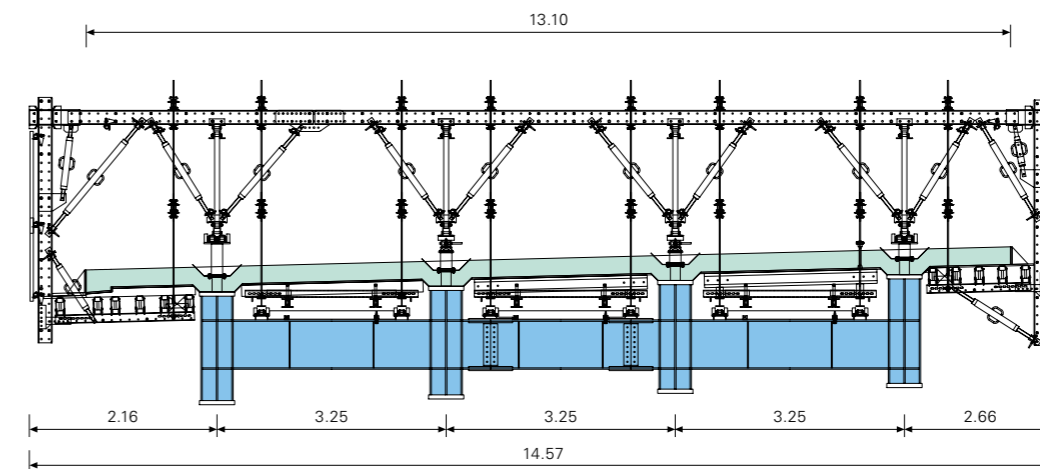

The loads from the 25 cm thick carriageway slab were reliably transferred into the steel girders via the VARIOKIT composite formwork carriage.

With the help of the two formwork carriages and two additional sets of slab formwork in advance, the up to 22.50 m long field and pier concreting cycles could be carried out using the so-called back-step method.

With the diagonal spindles, all inclinations and heights for the cantilever formwork could be easily adjusted.

The two parallel superstructures of the 22-field bridge were built using the steel composite construction method.



## Oparno Motorway Bridge, Czech Republic

Comprehensive system solution for arched bridges



For the 258 m crossing of the Oparno Valley, strict environmental protection regulations resulted in a bridge construction without any piers. With the arch cantilever construction, all adjustments needed due to the continuously changing arch geometry as well as compensation for any self-loaded deformations can be carried out accurately, simply and quickly. The PERI solution took into consideration temporary suspension measures during assembly along with the constraint points for the pier starters and at the apex.

The D8 motorway crosses the Oparno Valley, located in the Bohemian area of the Czech Republic, on two parallel positioned arched bridges at a height of 50 m. In a joint Czech-German collaboration, PERI provided an all-in-one comprehensive and cost-effective solution based on a standardised modular system. Using mostly rentable system components from the VARIOKIT engineering construction kit, RCS rail climbing system as well as PERI UP modular scaffold, piers, arched supporting structures and superstructures could be economically built – optimally adapted to the individual project requirements. The reinforced concrete arches have a span of 135 m, with a total length between both abutments respectively of 258 m.

Using the cantilevered construction method, the arches were formed and concreted in five to six-metre long sections with the help of two customised formwork and scaffolding units. Hydraulic units allowed the moving procedure of the arch cantilever construction to be carried out, mostly without crane support, regardless of the weather. The VARIOKIT engineering construction kit formed the basis of the spanwise construction of the double-webbed T-beam cross-sections. The 53 metre-long formwork carriage and the formwork system itself were optimally configured to one another and mobile hydraulic devices allowed the entire striking and shuttering procedures to take place as conveniently and

simply as possible. During the construction of the piers, the RCS rail climbing system served as climbing formwork scaffold for supporting the VARIO girder wall formwork. The mobile RCS self-climbing concept minimized the costs incurred here for crane-independent climbing. With just one system, the extremely versatile PERI UP Rosett modular scaffold solved numerous construction tasks: for reaching and assembling the temporary bracing for the arched supporting structure, stairs and access ladders as well as working platforms were used; in addition, the PERI UP protective roof construction ensured that rail services in the valley continued to operate as usual during the project without any negative effects on buildin.



**Roman Šimáček**  
Site Manager

“The very strict environmental protection regulations meant that a technically challenging bridge construction was necessary. PERI provided us with a perfect customised, economical and safe solution for the piers and arched construction along with the superstructure.”

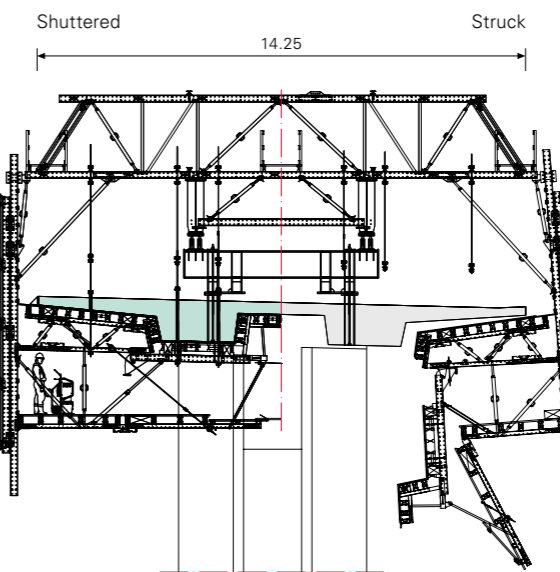

**Contractor**  
Metrostav a.s.,  
Division 5, Prague  
**Field Service**  
PERI Prague, Czech Republic,  
and PERI Weissenhorn, Germany

The VARIOKIT formwork carriage for the T-beam cross-sections – left, shuttered in a concreting position and right, striking has taken place and the formwork folded down ready to move.

The bridge piers were cost-effectively and crane-independently climbed with the PERI RCS rail climbing system.

Cost-effective system solution: the VARIOKIT formwork carriage was load-optimised and geometrically adapted to match the two 14-metre wide T-beam cross-sections.

For moving past the bridge piers, the slab formwork was hydraulically folded downwards – an easy and straightforward operation.



## Bridge Renovation, Ponte Rio Tua, Vila Real, Portugal

Adaptable scaffolding system accelerates bridge refurbishment



Safe working areas for a wide range of renovation work: strengthening of the roadway surfacing and the T-beam construction, repairing the concrete and corroded reinforcement. The epoxy injection method was used to fill the cracks whilst walkways and guardrails were reconditioned. Subsequently, the entire bridge deck was re-coated.

The 70-year old reinforced concrete arched bridge which crosses the Rio Tua in Northern Portugal had to undergo extensive refurbishment. It has a total length of 120 m and is 8 m wide. The concrete arch has a 80 m span and the superstructure is supported on a number of piers in between the abutments. With PERI UP Rosett Flex, safe access was provided to all structural components and

load-bearing working platforms for renovation work to be carried out. The ground contact area for the up to 20 m high scaffolding was 7 m wide. At the highest point, the scaffold is 11.75 m wide. The lateral cantilevers along with the bridging between the outer bridge piers were realized with PERI UP system diagonals without the need of any additional auxiliary components. For this, the standards

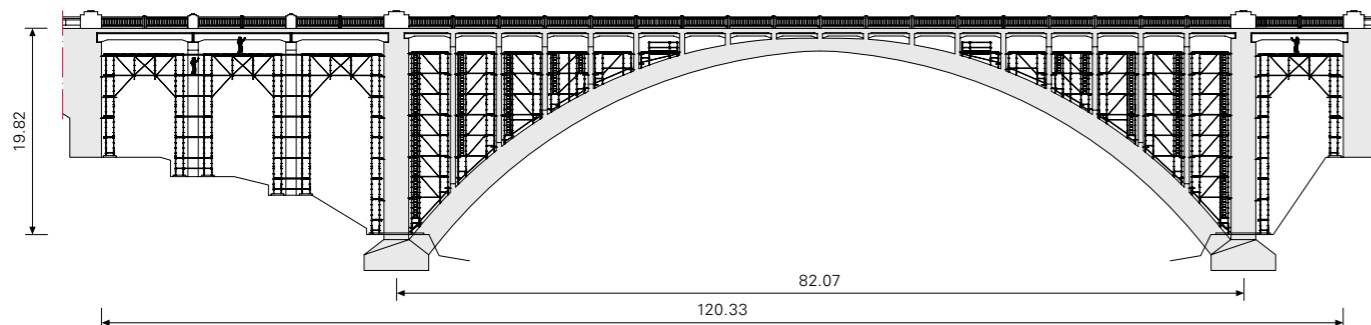

**Bernardo Carmo**  
Site Manager

"In addition to fast assembly, PERI UP provides high load-bearing capacity. As a result, we could also work on the platforms with heavy materials and a crane was not required. Apart from this, the scaffold system was so flexible that any unexpected adjustment work due to inaccurate building plans did not adversely affect the scaffold solution nor construction schedule."

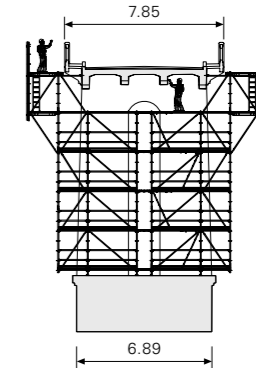

**Contractor**  
Conduril S.A., Ermesinde  
**Field Service**  
PERI Lisbon, Portugal

Despite the special shape of the concrete arch as well as the different sizes of the piers, every structural member could be tightly enclosed. The adaptability of the PERI UP system came in handy during assembly: although the drawings submitted for planning did not match site conditions, access means and platforms could be erected without requiring any time-consuming and expensive improvisation.

All PERI UP system components are compatible with each other. As a result, working platforms, stairs and guardrails are easy and simple to install. A 19 m high stair tower served as main access, with alternating staircase units and 75 cm flight width. Between the bridge piers, ladders were integrated which directly connected the working levels with each other.

were connected with the node braces which had already been attached, and simply swivelled outwards via the ledgers with the scaffolders always in a safe and secure position.

Through the flexibility of the modular scaffold system to the complicated bridge geometry, scaffold assembly as well as the renovation work could be accelerated. Improved accessibility along with increased working safety levels meant that construction time fell below the originally scheduled seven months. The fact that the scaffold bays were completely decked out with UDI decks avoided dangerous gaps which enhanced safety for site personnel during use.

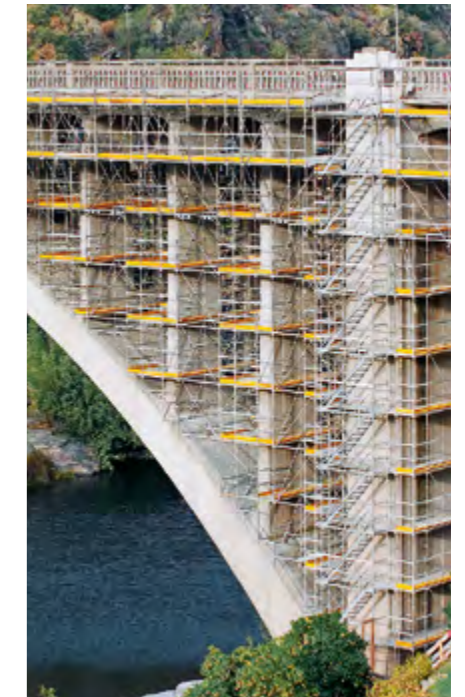

## Motorway Bridge D1, Považská Bystrica, Slovakia

### Cost-effective forming and shoring with PERI modular systems



With the "Centrum" D1 motorway junction, a 767 m long bridge structure, the cross-sections as well as its longitudinal and lateral inclinations change continuously. During construction, single and double-spaced hollow box cross-sections with variable superstructure widths had to be formed whereby two separate superstructures merged to form one distinct bridge structure. Planning and execution were based on rentable modular construction systems: construction of the hollow box cross-sections for the superstructure was carried out using PERI UP falsework, the external web formwork and cantilever formwork were created by means of variable raised formwork units using VARIOKIT

system components. PERI UP supporting scaffold transferred the vertical and horizontal loads from a height of over 15 m safely into the ground, and the required access means was also integrated. Through its modular structure and metric grid arrangement, the load-bearing system could be perfectly adapted to deal with all forces. With 150 cm, 75 cm and 25 cm ledgers, the individual load-bearing capacities of 40 kN per leg were combined to deal with higher loads – and virtually multiplied at will.

Even for concentrated loads as found in the web areas, several standards could be bundled together using system components. The hollow

box superstructure was realised in two casting segments with the help of VARIOKIT raised formwork units. In the first cycle, the bottom slab plus the webs were formed and concreted whilst the carriageway slab and cantilevers were formed in the second cycle. Using hinged and friction-locked connections with articulated walers and universal couplings, the latticed framework consisting of GT 24 formwork girders, SRU steel walers and SLS heavy-duty spindles could be accurately adapted to the structure's geometry and falsework.

For construction of the 767 m long motorway bridge, PERI's Slovakian engineers developed a formwork and scaffolding solution which perfectly suited the on-site requirements.

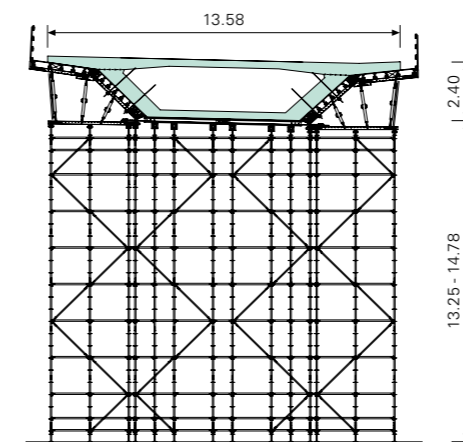
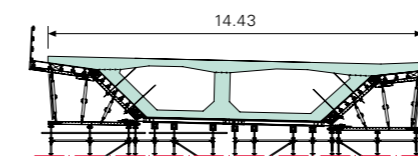
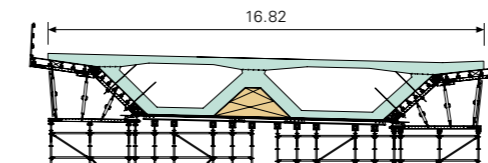
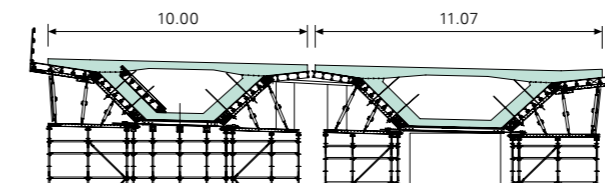
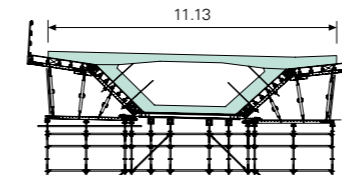

**Contractor**  
Bögl a Krýsl, k.s., Prešov  
**Field Service**  
PERI Senec, Slovakia



**Luboš Šalváry**  
Site Manager

"We have been working together with PERI for many years now and, once again, we have not been disappointed. For each bridge section, we received the perfect formwork and scaffolding solution."



Raised formwork units made of standardised system components taken from the VARIOKIT engineering construction kit formed the external web formwork and cantilever formwork and reliably transferred the loads into the falsework.



The span width is 34 m which also represented the length of each individual concreting cycle. For ensuring optimal building progress, the contractor had sufficient scaffolding material available for three complete construction phases: while two cycles are always completely scaffolded, the third set of materials is gradually dismantled, transported to and re-assembled in the next section.

Due to the constantly changing hollow box cross-sections, construction of the superstructure placed high demands on the variability and flexibility of the formwork and scaffold systems being used. At the junction point, two separate superstructures merge to form one distinct bridge structure.

## Saadiyat Bridge, Abu Dhabi, United Arab Emirates

Inclined piers and impressive superstructure constructed with system formwork



**Jens Nagel**  
Deputy Project Manager

“From PERI, we are used to getting reliability – for the technical support and the systems. The formwork solution used with VARIO and raised formwork units is extremely stable and the the PERI UP modular scaffold is easy to install and flexible in use. The moving procedure is carried out with large-sized transportable units.”

The flexible PERI UP scaffold system can be adapted geometrically tight and to suit every loading case. Even for tightly-spaced working areas, tidily arranged PERI pallets and transport containers ensure uncluttered storage areas and fast transport of materials.

The Saadiyat Bridge connects Abu Dhabi City and Saadiyat Island – an island which lies about 500 metres off the coast. With a length of 1,455 metre long and an impressive width of 60 metres, the construction is one of the widest bridges in the world. Eight foreland piers in the west and a total of eleven on Saadiyat itself serve to support the three pre-stressed concrete hollow boxes with spans ranging between 45 and 135 m. The main bridge has a span of 200 m and is carried by two V-shaped, 20-metre high identical sets of piers per section. The formwork and scaffolding solution for the individual supports, with inclinations of more than 27°, consists of two sets of VARIO GT 24 side formwork, a forward-inclined VARIO formwork element with integrated working platforms as well as a reverse-inclined raised formwork unit. Due to the high concreting loads, this was carried on PERI UP shoring.

The bridge piers were constructed alternatively in four climbing steps with concreting cycle heights of 4.70 m as well as by 2.44 metres in an outward direction in each case



due to the pier inclination. The PERI concept allowed the supporting frame construction to be pulled outwards on the steel girders after striking had been completed as though being guided along rails. For efficient realization of the required supporting and platform levels, three tower modules each with a 2.00 m base and a 4.65 m extension height could be vertically coupled together. Connections were carried out with the time-saving PERI section

**Contractor**  
ARGE Ed. Züblin AG and  
Saif Bin Darwish Engineering Contractor  
**Field Service**  
PERI Nuremberg and Weissenhorn, Germany  
and PERI Dubai, United Arab Emirates



Development of the eastern foreland bridge was carried out on falsework in 55-metre sections using pre-assembled raised formwork units consisting of rentable PERI system components.



**Alexander Schmalz**  
Site Manager

“With the PERI formwork solution for the cantilevered construction, it was possible for us to minimize the work involved for adapting to the different bridge cross-sections from cycle to cycle.”

structure formwork. For the construction of the pre-stressed concrete hollow boxes, three different building methods were used: the western foreland bridge was realized using the incremental launching method, for the superstructure on Saadiyat Island in the east, falsework served as a flat and even support, while the large spans in the middle bridge section are concreted by means of the balanced cantilever method.

In addition to both V-shaped piers in the centre of the bridge, 19 foreland piers for each of the three hollow boxes were built.



# Ponte Strallato, Cagliari/Sardinia, Italy

Flexible solution for a complex bridge construction



Stair access to the PERI UP working scaffold, which nestled up close to the tip of the pylon thus ensuring safe assembly of the cable-stays.

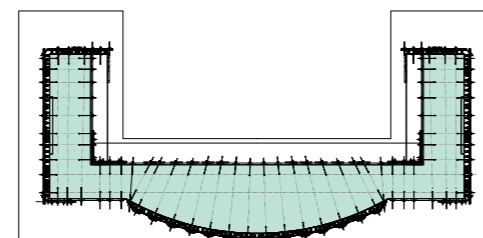
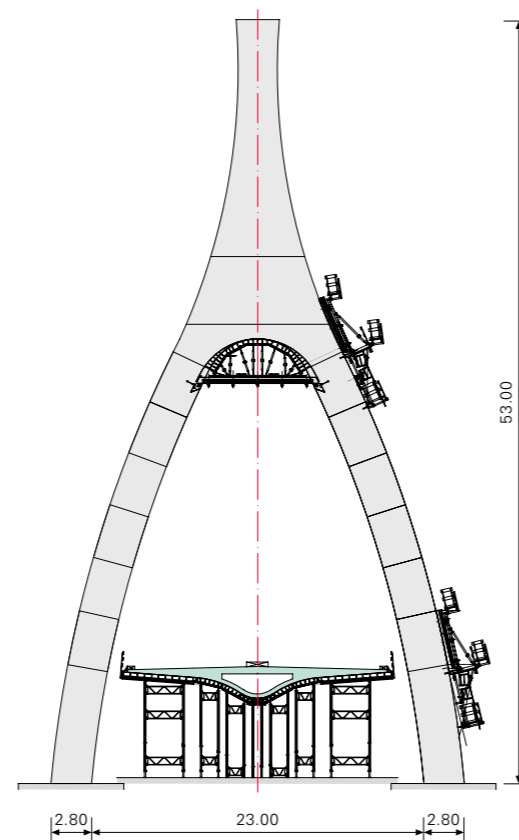

**Contractor**  
Ing. Raffaello Pellegrini SRL, Cagliari  
**Field Service**  
PERI Basiano, Italy

Highway SS554 has significantly eased traffic congestion in the island capital Cagliari in the south of Sardinia. An important feature of the infrastructure project was the 85 m long Ponte Strallato cable-stayed bridge. The bridge pylon is shaped like an upside down letter Y but has no straight edges and surfaces as well as being inclined backwards in a longitudinal direction.

The varying cross-sectional shape required a flexible formwork solution, which was developed by PERI's Italian engineers using SKSF 240 climbing scaffold and VARIO GT 24 girder wall formwork.

The rentable climbing formwork combination was cost-effective and could be optimally adapted to the set geometry and load. The complex form of the vertex arch demanded a special solution:



**Elia Pesche**  
Site Manager

"The bridge pylon with its arch-shaped geometry and continually variable ground plan dimensions required a great deal of flexibility. With the selected PERI formwork systems, we were able to optimize the individual construction phases and achieved high standards of quality and safety."

supported on project-specific steel brackets, a raised formwork construction comprised of PERI system components ensured safe and accurate construction. VARIO could be used flexibly here as well. The top section of the pylon was scaffolded on all sides with

PERI UP Rosett so that the steel cables for the bridge suspension could be safely positioned.

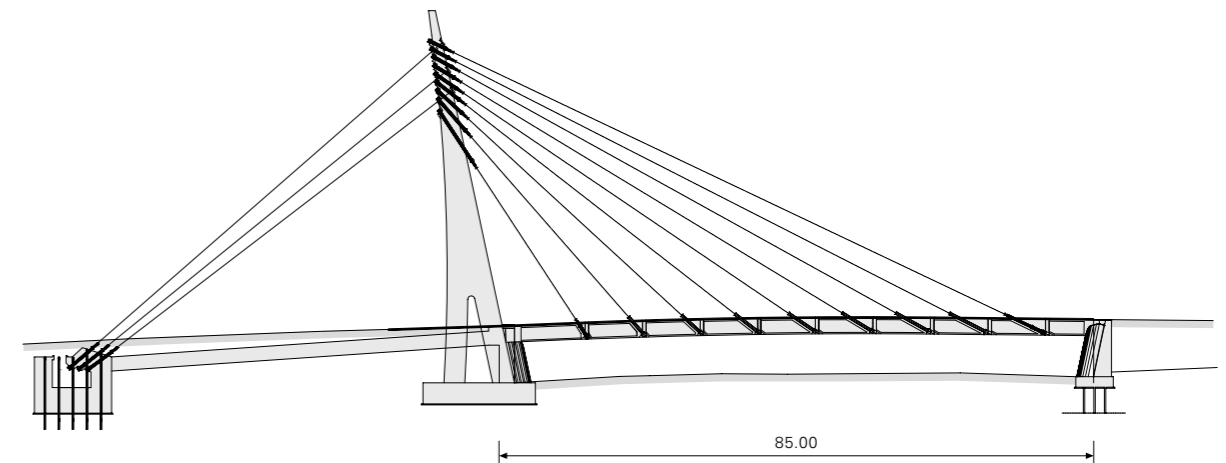

The bridge abutments were formed with TRIO, the curved wall surfaces with RUNDFLEX. With the BFD alignment coupler as the only connecting part, the two systems could also be combined with each other.



The SKS climbing scaffold could be optimally adapted to suit the complicated pylon geometry. Accessing the work platforms was carried out through PERI UP scaffold stairs.



The formwork for the vertex arch was formed with the VARIO GT 24 girder wall formwork system and stored on internally mounted special brackets.

## Térénez Bridge, Crozon, France

Unique cable-stayed bridge accurately and safely formed



**Antoine de Cambourg**  
Senior Project Manager

“With the ACS and VARIO solution, it was possible for us to realize the changing forms of the architecturally challenging bridge pylons. PERI engineers also provided our construction site team with great support during the project.”

**The 515 m long cable-stayed bridge connects the Bretonic mainland in the north-west of France with the Crozon peninsula. One special feature is the fact that the steel cable-stay supported superstructure is curved in plan and the unique geometry of the pylons form the Greek letter Lambda. The main span is 285 m and the two pylons each reach a height of around 100 m.**

On basis of ACS self climbing technology and the VARIO GT 24 of girder wall formwork system, a solution was

**Contractor**  
Sogea Bretagne, Brest  
Dodin Campenon Bernard, Toulouse  
**Field Service**  
PERI Meaux, France and  
PERI Weissenhorn, Germany



The very unusual bridge architecture comes across as a new landmark but nevertheless blends into a landscape which has been shaped by the rough Atlantic conditions.



With regular concreting cycle heights of 4.00 m, the PERI formwork climbed from cycle to cycle – with up to 20° inclined surfaces.

developed which, on the one hand, worked crane-independently in all weathers and, on the other, also provided maximum safety. Because in addition to the complicated pylon geometry, high safety requirements were also to be maintained. With help of the ACS climbing device, all four pier sides could be climbed together at the same time without intermediate anchoring. As a result, the working platforms were secured at all times without requiring any additional measures. The flexibility of the VARIO system allowed the construction crew site to accurately adapt the wall formwork to the continuously changing geometry. This led to smooth and trouble-free construction progress and perfect concrete results.

Due to the different inclinations of the pier shafts, the continuously adjustable ACS V was used. Concreting, working and finishing platforms could always be positioned horizontally thus ensuring safe and comfortable working conditions – and through the horizontally-adjusted carriage which moved the formwork easily and safely.

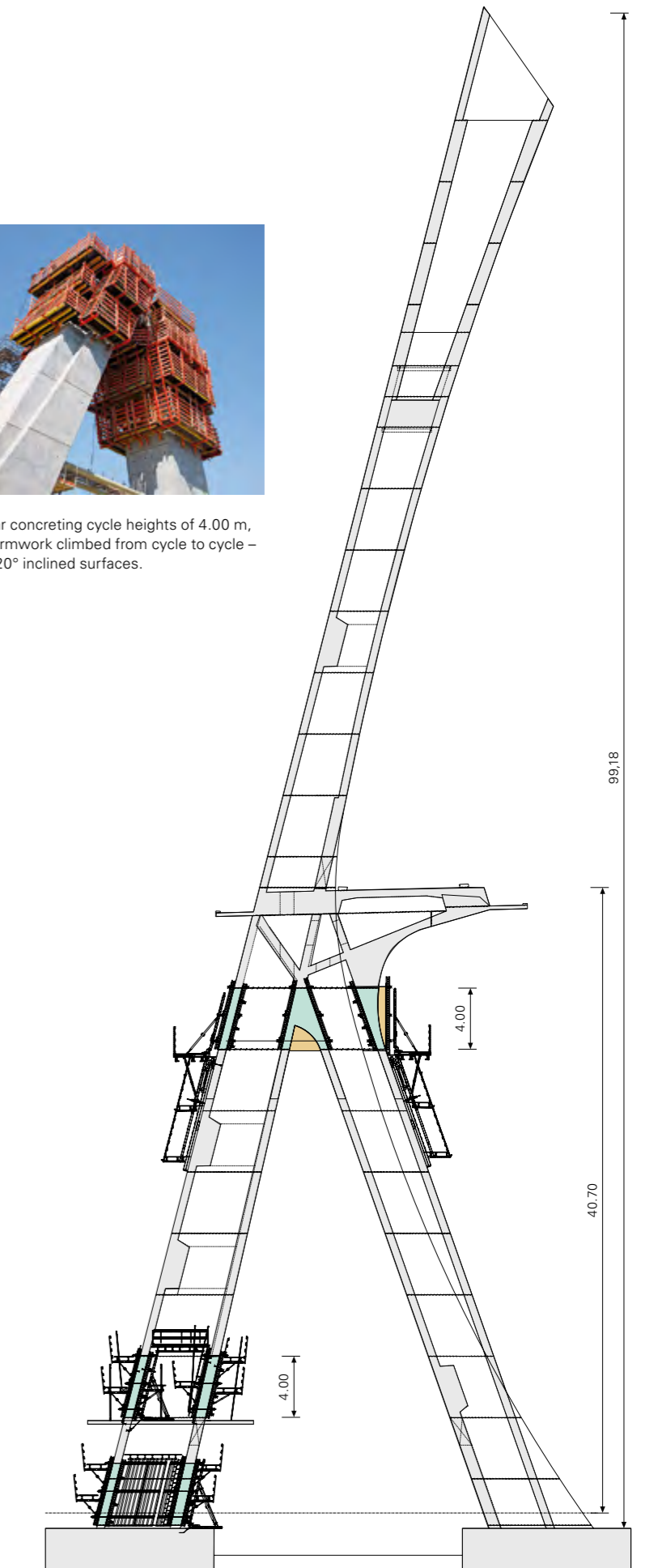

## Puente Baluarte, Mexico

Highest bridge in Latin America efficiently climbed



**The Baluarte Bridge is one of the most outstanding infrastructure projects in Mexico. PERI planned and supplied a cost-effective formwork and scaffolding concept for the construction of the bridge piers as well as the up to 170 m high pylons. The ACS self-climbing formwork allowed crane-independent climbing in all weather conditions which significantly accelerated the construction progress.**

The 1,124 m long cable-stayed bridge crosses a ravine which has a depth of

almost 400 m, and is ranked the third highest bridge in the world. The main span of the structure is 520 m long whilst the 20 m wide superstructure is supported by two pylons and nine bridge piers. P5 is the highest pylon and reaches a height of 169 m with the topmost point of its neighbour ending 13 m below this. The cross-section of the pylon base measures 18.00 m x 8.56 m which widens to 31.30 m in the carriageway centre, and then tapers upwards to 8.00 m x 4.10 m at the top. For the construction of this complex geometry, PERI developed a self-climb-

ing solution on the basis of the ACS system. For the forward and reverse-inclined external walls, the platforms could be continuously adjusted to match the angle of inclination which meant that horizontal working levels were always available. As formwork, the flexible VARIO GT 24 girder wall formwork system was used. The formwork elements were designed so that they could be quickly adapted by the construction team to suit the requirements of the 46 or 49 concreting sections with variable concreting heights of between 3.28 m and 3.90 m.

The foreland piers were designed as double piers and vary in their height up to a maximum of 145 m – according to the shape of the terrain. Most surfaces could be realized with VARIO GT 24 standard elements. For the tight inner areas, PERI delivered tailored pre-assembled elements to the jobsite which exactly matched the geometrical and static requirements. Externally, VARIO together with CB 240 brackets formed large-sized climbing units whilst in the internal area of the double piers, shaft platforms were realized with the help of BR platform beams.

13.50 m high PERI UP shoring carried the formwork for the cross beams during construction. In the cantilevered areas of the working platforms, PERI UP Rosett Flex was assembled with a 1.50 m x 1.50 m basic grid. In the supporting, heavily loaded area underneath the massive reinforced concrete cross members, grid dimensions could be reduced by the installation of 25 cm walers which increased the load-bearing capacity of the scaffold.

#### Contractor

TRADECO Infraestructura, S.A. de C.V.V.

#### Field Service

PERI Cimbras y Andamios S.A. de C.V., Huehuetoca and PERI GmbH Germany, Weissenhorn Office

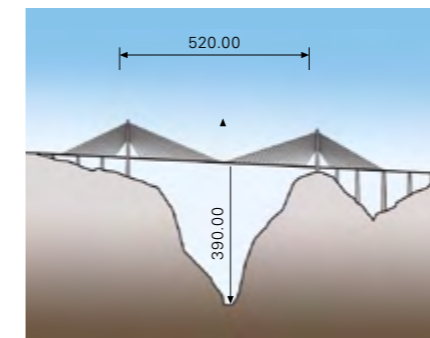

The bridge over the almost 400 m deep Baluarte ravine has a total length of 1.1 km with a span of 520 m.



**Salvador Sánchez Núñez**  
Project Manager

“We are extremely satisfied with the PERI systems and the very efficient engineering – climbing cycles could be greatly accelerated with the help of the ACS. In spite of the great heights, operations could be carried out safely on the working platforms. In addition, we achieved excellent concrete surfaces and our client is very satisfied.”



The formwork for the double-pier cross beams was supported with the help of PERI UP shoring up to 13.50 m high.

The two complex-shaped pylons were safely and accurately climbed with the ACS self-climbing technology to heights of 156 m and 169 m.

## Bridge over the Danube near Beška, Serbia

Parapet construction of 130 m per week across the Danube



**Claudia-Maria Graber**  
Site Manager

"It was a positive challenge for us to work simultaneously and safely with four formwork carriages – and thus comfortably maintain our tight schedule."

**Contractor**  
ARGE DSD/Alpine Bau GmbH  
**Field Service**  
PERI – Oplate d.o.o., Belgrade Office and  
PERI GmbH Germany, Weissenhorn Office



Two groups of VARIOKIT formwork carriages worked simultaneously – for realizing the weekly completion of six casting segments.



PERI UP suspended scaffold served as safe access means to the bearing points on the pier heads.



With CB/VARIO climbing formwork units, the 40 piers of the foreland bridge could be cost-effectively constructed.

**A total of four VARIOKIT parapet carriages operated at the same time which resulted in the regular completion of six concreting sections per week with a parapet length of 130 m.**

Parallel to the existing bridge structure, the Danube crossing near Beska has been complemented by a so-called twin bridge. As a result, a subsequent, continuous four-lane expansion for the E75 motorway between Belgrade and Novi Sad has been made possible. On the southern side, a 180 m long foreland bridge is joined to the 540 m long main bridge which is supported on three river piers, and the almost 1,500 m long approach bridge to the

north also crosses a floodplain of the Danube river. For the over 2.2 km long Danube bridge, PERI engineers worked closely together with the site management team to develop a common formwork concept which envisaged the use of the VARIOKIT parapet carriage that was to be operated from above. As a result, no additional mounting components, such as anchor sleeves, were required on the underside. In addition, the standardized assembly system minimized the planning effort – and ensured maximum flexibility of the formwork carriage solution when adapting to local site conditions. Two formwork carriage groups, each with four coupled VARIOKIT formwork carriages, worked in parallel.

This meant that six casting segments, each 21.50 m long, could be realized in only five days – 130 linear metres of parapet per week. One of the formwork carriages also took into account the designated points of the parapet widening in order to accommodate the lamp posts. Simple and thereby fast shuttering and striking procedures, as well as the systematic concreting sequence, ensured rapid progress for constructing the parapets with a total length of 4,440 m. In this way, the construction team was able to maintain the extremely tight schedule without any problems.

In addition, PERI supplied the climbing formwork for the construction of the 40 bridge piers with heights up to 50 m. CB 240 climbing brackets and VARIO GT 24 formed large-sized movable units with concreting cycle heights of 5 m. For the bridge piers with hollow box cross-sections, shaft elements made sure that the TRIO internal formwork could remain connected as a complete unit – as a result, valuable time-savings were achieved during the construction of the piers. PERI UP suspended scaffolds rounded off the comprehensive PERI project solution for the bridge over the Danube. This served as secure access to the bearing points on the pier heads.

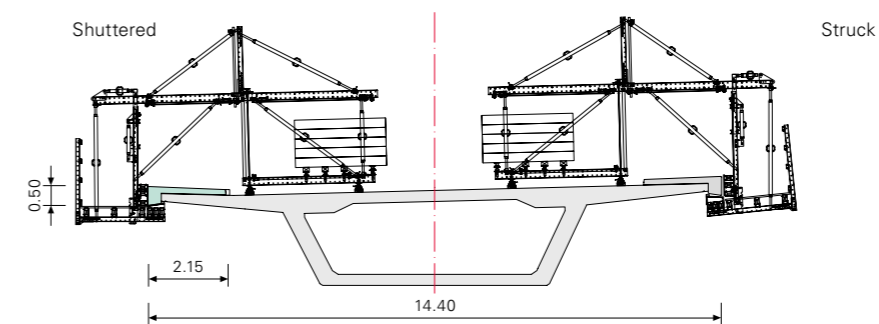

The VARIOKIT parapet carriage features load transfer via cantilever beams, requires no anchoring in the structure and can be optimally adjusted to suit jobsite requirements.

## Chachenka Bridge, Moscow, Russia

VARIOKIT cantilevered construction in 10-day cycles



**The 550 m long motorway bridge in the west of Moscow was constructed using the VARIOKIT balanced cantilever method. The Russian-Polish PERI teamwork tailored its bridge formwork solution to match construction site requirements.**

The motorway bridge over the Chachenka River is an integral part of the 18.5 km long road construction project that connects the Moscow MKAD motorway ring with the M1 highway as well as bypassing the town of Odintsovo which is situated to the west of the Russian capital. Known simply as the “Belarus”, the M1 between Moscow and Minsk

in Belarus is one of the most important road connections in Russia.

The bridge structure is 550 m long and consists of two parallel superstructures with double-cell hollow box cross-sections, each 22.25 m wide and 4.00 m high. The individual span widths of the six bridge segments range from 57 m to 110 m, realized using the balanced cantilever method. A total of 10 sets of VARIOKIT balanced cantilever equipment were used simultaneously in order to symmetrically realize – starting from the piers – each of the 12 sections with cycle lengths between 3.40 m and 4.10 m until the gap was closed in regular 10-day cycles. PERI Russia delivered the

cantilevered construction carriage and formwork from a single source, optimally adapted to match the project requirements. In addition, the use of rentable VARIOKIT system components was extremely cost-effective. Shuttering and striking along with moving from cycle to cycle was carried out with only a team of six. Through the compatibility with the PERI UP modular scaffold, front-mounted working platforms and access means were also part of the comprehensive PERI project solution.

**Contractor**  
OOO «SGC Autostrada»  
**Field Service**  
OOO PERI Russia, Noginsk/Moscow  
PERI Poland Sp. z o.o., Warsaw



**Konnyh Aleksandr Andreevich,**  
Head of Production and Engineering  
**Zamaletdinov Fatih Nailovich,**  
Site Manager

“With the VARIOKIT balanced cantilever equipment from PERI, we could realize the superstructure sections and in the planned working rhythm. On-site assembly was also carried out very quickly.”

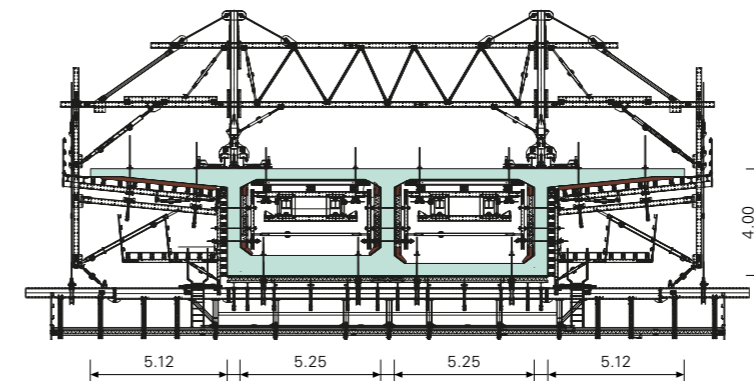

The VARIOKIT formwork carriage solution could be flexibly adapted to meet the individual project requirements. For the first concreting section – due to the limited space available on the starter section – using the rails of the balanced cantilever equipment here resulted in more overhang than usual.

The 22.25 m wide superstructure sections were constructed with section lengths ranging from 3.40 m to 4.10 m in regular 10-day cycles.



For safe working platforms and access, VARIOKIT and PERI UP could be ideally combined.



Apart from the VARIOKIT balanced cantilever equipment, the CB/VARIO climbing formwork was also an important part of the PERI project solution.

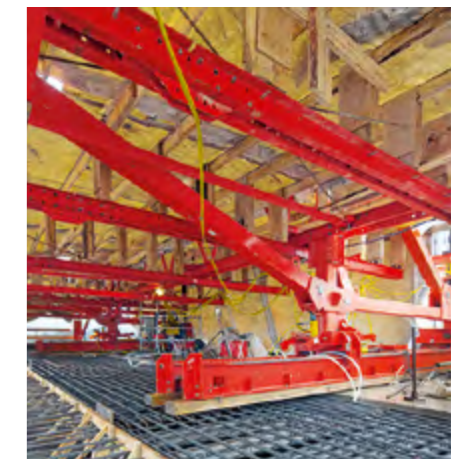

# Trans-Rhumel Bridge, Constantine, Algeria

## System solution for a complex bridge construction

**Contractor**  
 Andrade Gutierrez/Zagope, Oeiras, Portugal  
**Field Service**  
 PERIcofragens, Lda. Portugal, Queijas  
 SARL PERI Algeria, Algiers Office  
 PERI GmbH Germany, Weissenhorn Office



**With the help of the 3D planning, PERI engineers developed a project solution on the basis of mainly rentable system components. The individually designed and flexibly adaptable superstructure formwork with a well thought-out cycle sequence saved valuable construction time.**

The 750 m long cable-stayed bridge – supported by two 130 m high pylons and six bridge piers – is an integral part of the 6 km long urban motorway project. This has helped to reduce traffic congestion in the city centre which features a number of historical bridge structures. Four lanes, with sidewalks on both sides, cross the gorge-like Rhumel Valley at a height of 80 m. The single-cell hollow box cross-section features an extraordinary width of almost 30 m.

For its realization, which included diverse project requirements, the team of Algerian, Portuguese and German PERI engineers working in close collaboration developed efficient formwork and scaffolding solutions. One of the biggest challenges was the bridge superstructure above the pier heads. The complicated geometry with differing cross-section widths as well as varying longitudinal and transverse inclinations resulted in complex intersections. For this, PERI developed a 3D-based, technical concept which was easy to understand and implement



**Nelson Vasques**  
 Project Manager

“With PERI as our partner, we could handle our project without any problems and very cost-effectively. The systems used allowed efficient and fast working operations, whilst the on-site support was positive and extremely helpful.”

Each superstructure section on the six bridge piers had different geometries and complex intersections, and were realized in four height and three longitudinal concreting cycles.

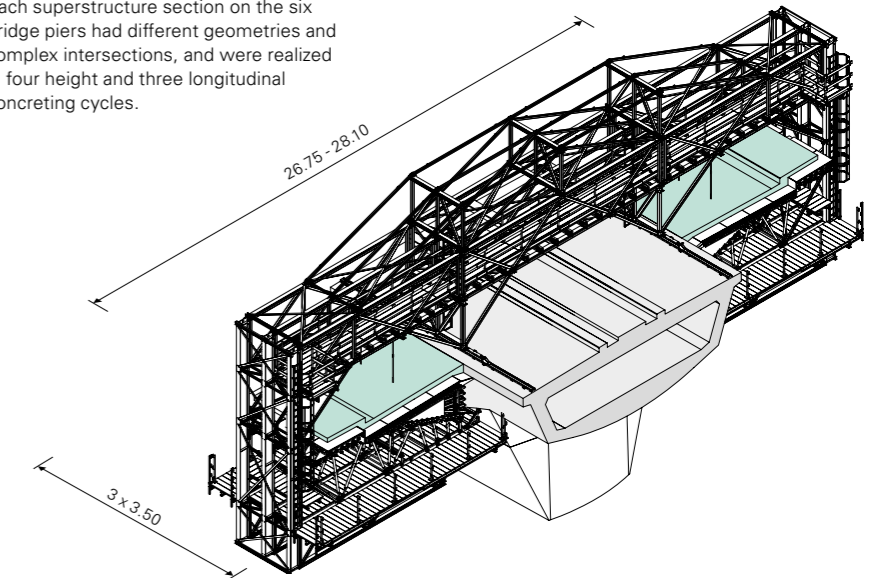

without any problems on the jobsite. The use of rentable system components, in connection with

project-specific steel components, proved to be the most cost-effective option.

The 8 m carriageway slab was constructed in the area of the pier heads in three sections each with a 3.50 m cycle length.

The new cable-stayed bridge bypasses the old town of Constantine with its historic bridges, crossing the deep Rhumel gorge.



Up to 28 m high VARIOKIT heavy-duty shoring towers, combined with PERI UP, supported the bridge superstructure in the edge sections.

For the slab and web formwork of the starter, PERI engineers combined horizontally-positioned brace frames with VARIOKIT frame construction units.

## Dalsfjord Bridge, Norway

Self-climbing formwork with access technology



**On the basis of the ACS and RCS self-climbing technology, the VARIO formwork climbed the pylons hydraulically and without the need of a crane. In addition, a 90 m high PERI UP stair tower provided site personnel very safe access to the working platforms.**

50 km north of Bergen, a 523 m wide suspension bridge majestically spans the Dalsfjord. The two H-shaped pylons are both around 100 m high and the upwardly tapering cross-sections of the double piers are designed with external pilaster strips.

With the help of the PERI self-climbing solution, the construction team was able to complete the 24 concreting sections in regular weekly cycles – crane-independent and regardless of the weather. For this, PERI engineers combined the external ACS self-climbing system with the rail-climbed RCS positioned on the inside. The VARIO girder wall formwork as part of the climbing units provided the required shaping. A PERI supervisor briefed site personnel during the initial assembly and operational start-up of the climbing formwork, and ensured fast construction progress from the very beginning.

Not only was the connecting bridge between the two sets of pier formwork an integral part of the PERI formwork solution: a stair tower on the basis of the PERI UP Rosett scaffolding system provided safe access to the respective working platform. The stair tower featured alternating staircase units with 64 cm wide flights of stairs – and continuously extended in accordance with construction progress up to 92 m high. The stairs were anchored at regular intervals with PERI push-pull props in order to safely bridge the ever-growing gap to the inclined pylon shafts as the tower increased in height. For this, the existing anchoring points for the ACS could be used.



**Martin Schweizok**  
Project Manager

“The PERI systems are well thought-out, easy to understand and designed to meet individual requirements – no problems whatsoever for our construction team. As a result, we could maintain the tight construction schedule as well as meeting strict Norwegian safety requirements.”

#### Contractor

Bilfinger Berger Ingenieurbau GmbH  
BBS Schalungsbau GmbH, Bobenheim-Roxheim

#### Field Service

PERI GmbH Germany, Stuttgart and  
Weissenhorn Offices



The pylons were realized in 24 sections, each with 4 m concreting cycle heights – whilst taking into account inclined shafts and variable cross-sections.



A 90 m high PERI UP stair tower supplemented the complete solution which was developed through the excellent cooperation with the project management.



The ACS self-climbing scaffold steadily moved safely and smoothly upwards on climbing rails by means of a hydraulic drive system.

## Bridge over the Golden Horn, Istanbul, Turkey

Efficient forming and shoring with modular construction systems

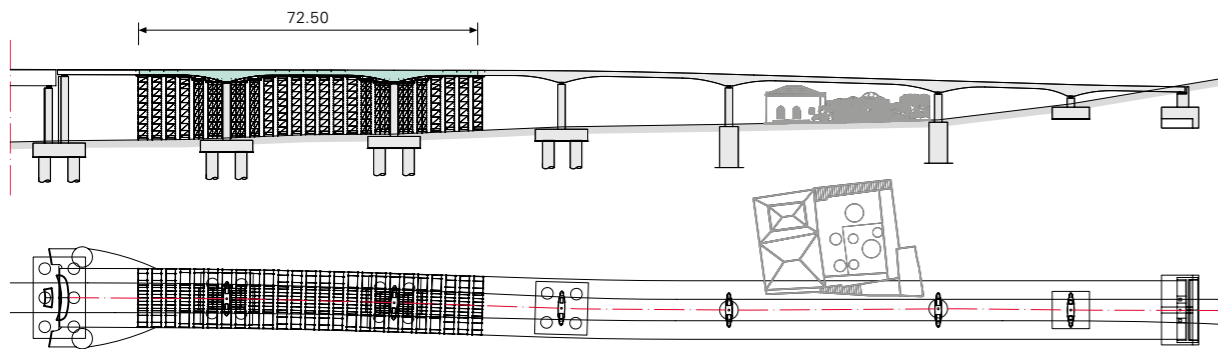

The thickness of the massive bridge superstructure changed continuously from 1.10 m to 2.50 m. Superstructure formwork and framework units could be easily adapted to suit the varying geometries and loads.

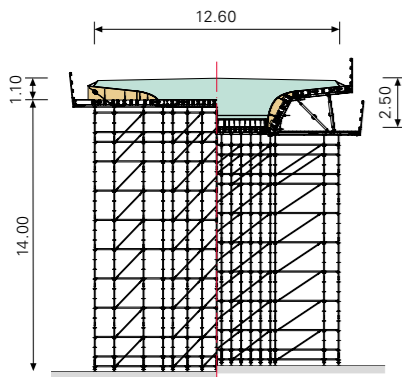

**Alper Uzman, Deputy Project Manager**  
**S. Ulaş Akı, Supervisor**

“Selecting PERI as our partner was definitely the right decision: from the beginning onwards, we worked out a range of optimal solutions together. Through an easy and simple adjustment of VARIOKIT and PERI UP to suit the variable geometry, productivity could be increased as well as achieving safe construction progress.”

**The combination of detailed planning work, continuous site supervision and optimized system use was the basis for ensuring fast construction progress and excellent quality of execution.**

The bridge over the Golden Horn (Turkish: Haliç) connects the historical, millennia-old Istanbul with the modern, European-influenced districts of the city. It is an integral part of the urban transport system expansion programme in an effort to cope with the increase in traffic volumes: two 950 m long subway tracks cross over the famous Bosphorus Straights. The new connection is a combination of cablestayed and swing bridges as well

as a 450 m foreland bridge. The construction of the single-webbed T-beam cross-section superstructures in the foreland areas was realized on PERI UP falsework. Web and cantilever formwork were formed with variable frame construction units comprising of VARIOKIT system components due to the continuously changing cross-section. With the help of CNC-milled formwork units prepared at the PERI formwork assembly hall, the distinctive form of the bridge underside could be realized through curvatures in the transverse and longitudinal directions.

Framework units on the basis of the PERI UP Rosett Flex modular scaffolding formed the supporting structure for

transferring the vertical and horizontal loads. The supporting heights of between 1 m and 14 m could be flexibly realized whilst the framework unit width was maintained at a constant 2.00 m. In the area of the piers, the carriageway slab is up to 2.50 m thick: here, the shoring tower width was halved with the legs bundled in 50 cm x 100 cm grids.

The bay lengths in the direction of the frames could also be adapted to suit the web and cantilever thicknesses – in 25 cm increments by means of system ledgers without any additional effort.



Optimized load transfer: superstructure formwork and falsework for the foreland bridges based on the flexible VARIOKIT and PERI UP modular construction systems.



The VARIOKIT framework units transferred the loads into the shoring while the curvatures in the transverse and longitudinal directions were formed with formwork units.



With the help of the PERI UP Rosett Flex modular scaffolding system, adaptations could be made to accommodate any obstructions.

### Contractor

Astaldi – Gülermak J.V.V.

### Field Service

PERI Kalıp ve İskeleleri San. ve Tic. Ltd.Şti Turkey, Istanbul

## Vistula Bridge, Kwidzyn, Poland

Crane and weather-independent modular solutions



**With the help of PERI modular solutions for all formwork and scaffolding tasks, the Vistula Bridge could be realized within a very tight construction schedule – largely independent of crane and weather.**

The Vistula crossing near Kwidzyn extends over a total length of almost 12 km. The most important components are the 808 m long main bridge and three foreland bridges. In spite of the different constructions, PERI provided a comprehensive overall solution – largely based on the VARIOKIT, RCS and PERI UP modular systems. The PERI concept for the main bridge included self-climbing formwork for the two bridge piers,

the superstructure formwork for the hollow box cross-sections with formwork carriage as well as the falsework for the edge sections. The parapet beams were formed with the help of the VARIOKIT formwork carriage which was customized to meet site requirements, anchoring in the structure was not necessary here. For the bridge piers, the TRIO formwork was climbed using the RCS rail-guided climbing technology – thanks to the mobile RCS self-climbing devices without a crane and regardless of wind and weather.

The superstructure of the foreland bridges, with a total length of 1,000 m, was carried out using the incremental

launching method – with the help of VARIO girder formwork, in 30 m casting segments in regular weekly cycles. A protective roof construction based on the LGS lattice girder system made the construction work weather-independent. An inside heating system ensured that working operations continued during the winter and consistently high concrete quality was achieved. When required, the weather protection roof took only a few minutes to open as the roof segments could be moved by hand without the use of a crane.



RCS climbed the bridge piers rail-guided – as well as crane-independent thanks to the mobile self-climbing technology.



ST 100 stacking towers served as falsework for the edge sections of the 808 m long main bridge.



**Mariusz Sasin und Tomasz Witkowski**  
Site Managers

“Due to the very tight construction schedule and the enormous formwork requirements, we needed a very reliable partner. With its high-level professional services and state-of-the-art solutions, PERI has completely met our expectations. For many years now, we have relied on PERI engineering and the comprehensive support – in particular the fast assembly, flexibility, quality and high level of safety of the PERI systems.”

**Contractor**  
BUDIMEX S.A.  
Ferroviar Agroman S.A.  
**Field Service**  
PERI Poland Sp. z o.o., Danzig Office

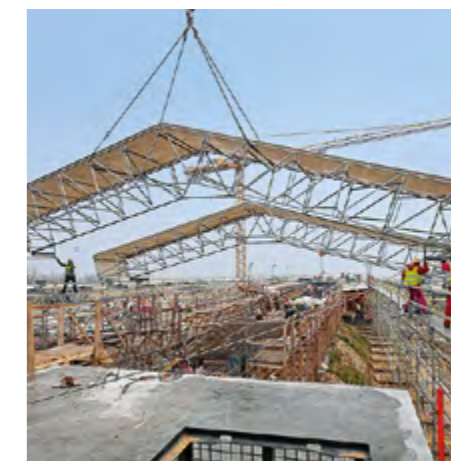

The LGS weather protection roof allowed continuous construction progress – regardless of the weather conditions.

## Lekki Ikoyi Bridge, Lagos, Nigeria

Two climbing systems ideally and safely combined



On the left, ACS for the inclined front sides; on the right, RCS with the mobile climbing hydraulics for the forward and reverse inclinations as well as rounded surfaces.



The superstructure is suspended along a length of 225 m on a 90 m high pylon by means of stay cables. Its efficient completion was ensured through the use of the ACS and RCS climbing systems which were combined to create a tailored formwork solution.

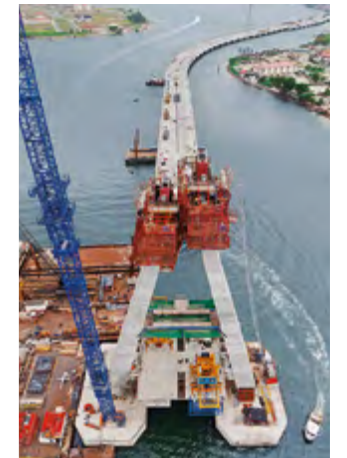

The Lekki Ikoyi Bridge connects two districts of the capital: Lekki, situated on a peninsula with the same name, and Ikoyi on Lagos Island.

**For the pylon of the first cable-stayed bridge in Nigeria, the ACS and RCS climbing systems were combined to create a project-specific solution, optimally adapted to suit all geometrical and safety requirements. In addition, crane-independent working operations ensured rapid construction process.**

A striking, 90 m high pylon characterizes the appearance of the 1.4 km long bridge structure. The 635 m long main bridge is suspended along a length of 225 m on a centrally-arranged individual pylon by means of stay cables. Up to a height of 50 metres, it is A-shaped. At this point, the pylon legs change to the shape of a fillet so that they also do not touch in the area of the cable anchorage – they are connected with each other by means of cross beams. In addition, the dimensions of the shaft hollow sections continuously taper and widen on the front side at the upper end.

The combined use of two self-climbing systems guaranteed efficient and safe working operations. For the forward and reverse inclinations as well as the fillet with a continuously changing angle of inclination, the RCS rail climbing system provided the optimal basis.

There was an articulated connection between the top and bottom climbing rails. As a result, the fillet section could therefore be climbed over at only a 77 m radius in sections with 3.60 m concreting cycle heights – without requiring any modification work on the formwork and working platform. With the help of mobile climbing hydraulics, moving procedures took place without a crane. The ACS self-climbing technology accelerated moving operations on the front sides. Even with the inclined climbing rail arrangement with angles of up to 14°, ACS ensured that the high loads could be reliably carried.

An important element of the overall solution was the integration of the access technology especially the connecting bridge between the climbing platforms. The so-called skywalk was joined to the inner platforms by means of an articulated connection and thus climbed automatically. The connection of the elevator to the RCS climbing platform was carried out by means of a telescopic platform. This compensated for the different spacings to the transportation cage at all heights – thus ensuring safe access to the working scaffold level at all times.

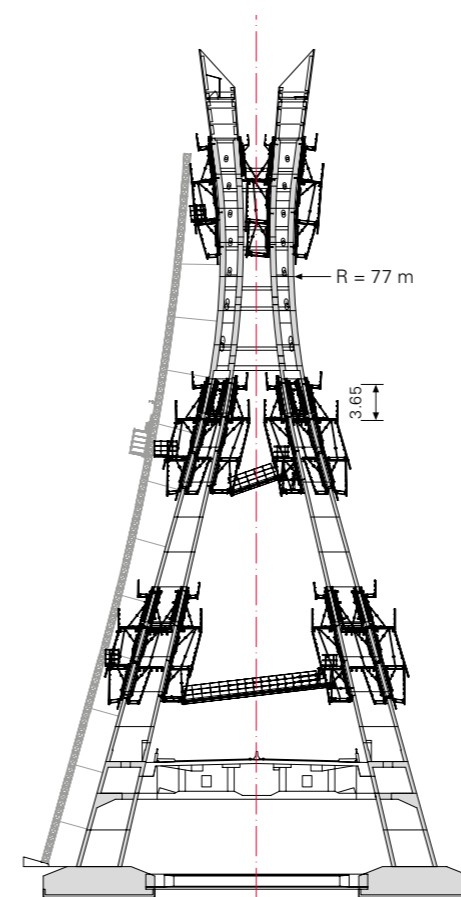

An important element of the PERI climbing formwork solution was the access technology with catwalk and elevator connection.



**Axel Schmitt**  
Site Manager

“The combined use of the ACS and RCS systems was the right decision. In spite of the complex geometry, it allows us to realize the pylon without any problems whatsoever – with completely safe working platforms at all levels and at any height.”

**Contractor**  
Julius Berger Nigeria PLC  
Planning Operations  
Julius Berger International GmbH, Wiesbaden

**Field Service**  
PERI Export Division Nigeria, Frankfurt and  
PERI GmbH Germany, Weissenhorn Office

## Puente Ejército, Lima, Peru

Steel arched bridge quick and safe assembly



**For assembling the steel arched bridge, PERI UP served as shoring and working scaffold at the same time. In addition, an important element of the scaffolding structure was the load-bearing capacity and load transfer into the sub-structure using system components.**

Two 105 m long steel arched bridges connect the northern district to the city centre of the Peruvian capital. These were positioned to the left and right of the 50-year old existing bridge in order to better manage the high volume of traffic through the expansion to 10 lanes as well as being able to accelerate the public transport system as a whole. PERI engineers created an assembly scaffold on the basis of the

PERI UP scaffolding system. This served as a temporary, up to 20 m high support structure for the steel segments as well as a working platform for the final assembly. Each arch consisted of 11 steel segments and had a total weight of 100 t.

A big advantage for the design of the shoring towers and working levels was the high load-bearing capacity and, in particular, the adaptability of the PERI UP Rosett Flex. In addition, system components from the PERI product portfolio supplemented the scaffolding structure: through the use of GT 24 formwork girders and SRU steel walers, the load distribution was also systematized. As an integral part of the PERI implementation planning and

static calculations, the stability of the structure could be extensively verified which led to shorter set-up times. The high flexibility of the PERI UP system enhanced safety conditions for the steel erectors and accelerated their work procedures. Then the different working levels were continuously connected in a longitudinal direction by means of system steel decks with side protection ensured through the use of ledgers. Due to the system grid of 25 cm or 50 cm, all adjustments can be carried out without any time-consuming tube and coupler connections; in particular, the self-securing ledger assembly with the "gravity lock" also increased the working safety for the scaffold assemblers.

The assembly of the 11 steel arched segments required temporary support and working levels with heights of up to 20 m.

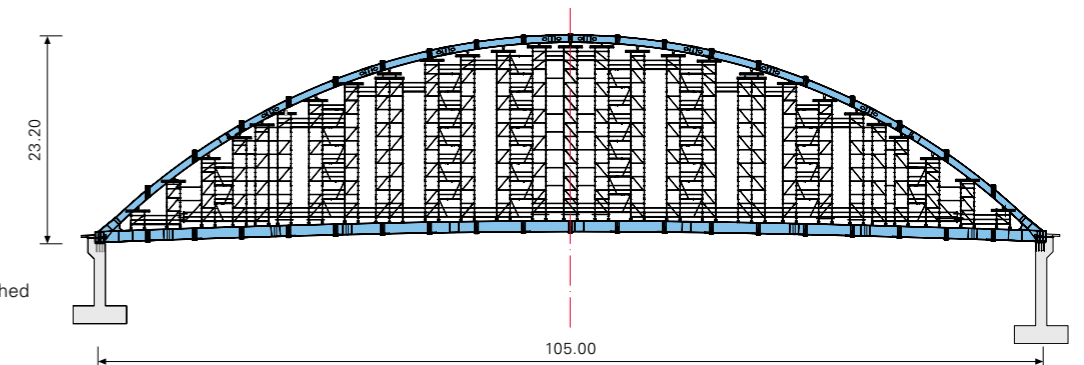

The PERI UP Rosett Flex modular scaffolding precisely matched the bridge geometry thanks to the system-integrated flexibility – without any time-consuming tube and coupler assembly.

Through the combination of PERI UP and system components of the formwork programme, loads could be reliably transferred.

Scaffolding and bridge assembly went hand in hand – with fast working speeds and maximum level of safety.



**Aristóteles Parra**  
Project Manager

"With the help of the PERI UP solution, assembly work on the steel arched bridge could be carried out faster and much safer."

**Contractor**  
COSEI Consorcio, Fianza  
**Field Service**  
PERI Peruana SAC, Lima

## Motorway Bridge V12 over the Rio Sordo, Vila Real, Portugal

Construction kit solution for falsework and superstructure formwork



**For construction of the motorway bridge over the Rio Sordo, VST heavy-duty shoring towers were used as falsework – 30 m high and with leg loads of up to 600 kN. Through the use of rentable system components taken from the VARIOKIT engineering construction kit for the superstructure formwork and shoring, the PERI solution was extremely cost-effective.**

The A4 motorway passes through the Marão Mountain Range in the north of Portugal. Near Vila Real, the route

requires the building of a 412 m long bridge for crossing the Sordo Valley which is in the form of a five-section structure with two separate superstructures. The almost 20 m wide and 3.60 m high pre-stressed concrete hollow box girders are being realized using two different construction methods: the three middle bridge spans with the balanced cantilever method and the respective edge spans formed on falsework.

As falsework, the contractor is using heavy-duty shoring towers from the

VARIOKIT modular system – 6 m to 30 m high with load-bearing capacities of 2,500 kN in each case. The VST towers were erected as four-legged individual structures which supported the 72 m long superstructure formwork at defined load application points with axis spacings of between 10 m and 24 m. Transversely, the tower measured 2.00 m in each case, longitudinally between 2.00 m and 7.50 m – depending on topographical and static requirements. In those areas which are subjected to particularly high loads, additional legs with axis spacings of



**F. Paiva, A. Monteiro, J. Campos, P. Rosa, J. Marques, L. Fidalgo**  
Construction Site Management Team

“The falsework support provided for the edge sections was the biggest challenge due to the difficult terrain. With VARIOKIT and especially the VST heavy-duty towers, we were presented with a very practical solution that was designed precisely for the given foundation areas. The concept could easily be implemented on site – combined with fast and safe assembly.”

**Contractor**  
INFRATÚNEL, Construtores do Túnel do Marão A.C.E., Porto  
**Field Service**  
PERIcofragens Lda Portugal, Queijas  
PERI GmbH Germany, Weissenhorn

37.5 cm provided an increase in the load-bearing capacities. This minimized material requirements as well as reducing the amount of assembly work resulting in an optimized utilization of the overall system.

The falsework was delivered to the construction site pre-assembled as 1.25 m to 10.25 m high variable frame arrangements, further extended on the ground to form tower segments, and erected and extended with the

help of a crane. Safe PERI UP working platforms are used to ensure accurate positioning along with fixing in place with bolts and pins. Together with the VST towers, these were continuously added to as required and were easily connected by means of corresponding adapter elements. In addition, both modular construction systems are based on a metric grid pattern so that the load-bearing system, working levels and access technology could be perfectly coordinated.

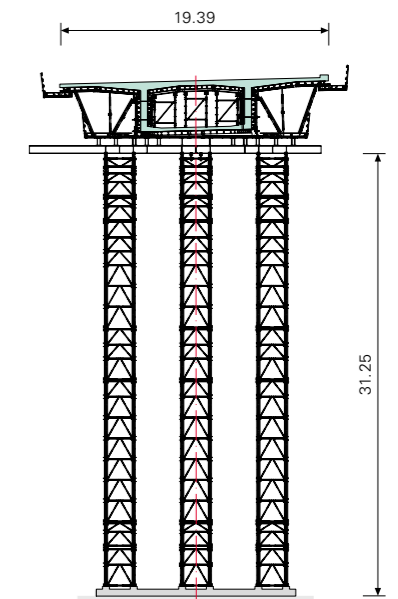

The difficult terrain required supporting heights ranging from 6 m up to more than 30 m.

Both the superstructure formwork as well as the falsework were based mainly on the VARIOKIT engineering construction kit.



The falsework for the edge sections was an important component of the formwork and scaffolding solution for the 412 m long motorway bridge.



The two modular systems VARIOKIT and PERI UP can be ideally combined.



## Motorway Bridge T4, Paradisia-Tsakona, Greece

### Supporting system solution – individually adapted



**Nikolaos Donas**  
Site Manager

“PERI convinced us with the best technical and most cost-effective formwork and scaffolding concept. Together with the PERI engineers, we were able to select the optimal system in each case – adapted to match the complex project requirements. Apart from technical support in the planning and during the construction phase, I would particularly like to highlight the on-site project support as well as the provision of materials in accordance with the construction schedule.”



Bundled 42-leg VARIOKIT shoring towers carried the extremely high loads in the connecting area of the steel arch connections.



By halving the 150-cm basic grid using 75-cm long ledgers, the PERI UP could be optimally adapted for the load concentrations.



PERI engineers combined two modular construction systems to form a comprehensive load-bearing concept with heights of up to 20 m.

**A huge inclined pier supports the motorway bridge on the Greek peninsula of Peloponnese. A team of Greek and German PERI engineers supported the site management team with projectspecific system solutions.**

The 160-km long A7 motorway connects the towns of Kalamata and Corinth. The principle element being used to close the gap between Paradisia and Tsakona is a 390 m long arched bridge. Two-thirds of the 22 m wide bridge superstructure is suspended on a steel arch and was constructed using the steel composite construction method. For the northern bridge section, a pre-stressed concrete superstructure variant was selected which features a twin-cell hollow box cross-section. Supporting element of the bridge is a huge, almost 30 m high,

inclined twin-pillar pier with an asymmetrical V-shape. On the one hand, this serves as an intermediate support for the in-situ concreted carriageway and, on the other, as support and starter section for the steel arch.

PERI developed a comprehensive formwork and scaffolding solution – for constructing the pier structure and reinforced concrete superstructure as well as providing temporary support for the bridge during the entire building project. Essentially, two modular construction systems were combined with each other in order to transfer the high loads safely into the ground. With help of PERI UP Rosett Flex, a spatial load-bearing structure for the piers and superstructure formwork was formed, gradually increasing up to the total support height of over 20 m to the rear and upwards respectively.

Using 25, 50 and 75-cm long ledgers, the 150-cm basic grid could be adapted extremely flexibly here to suit the geometric and static requirements. This allowed the polygonal 32° to 36° shallow-pitched inclined piers on both sides of the bridge to be constructed in eight segments, each 4.50 m long.

Trusses consisting of rentable VARIOKIT standard elements supported the obliquely-positioned VARIO GT 24 girder formwork and transferred the formwork and concreting loads of the inclined piers safely into the scaffolding. In addition, the VARIOKIT modular construction system formed the basis for the heavy-duty shoring. In the connecting area between the cast-in-place bridge and steel arch, two 17 m high, 42-leg heavy-duty shoring towers were used to accommodate the high loads – until the inherent load-bearing capacity was reached. Each tower was designed to carry loads of 1,200 t, as well as high earthquake and horizontal loads, due to the long utilization period. For load concentrations, four standard towers respectively, each with 2.00 m by 2.00 m axis dimensions, could be bundled by means of 37.5 cm additional frames – using only rentable system components and type-tested connection means.

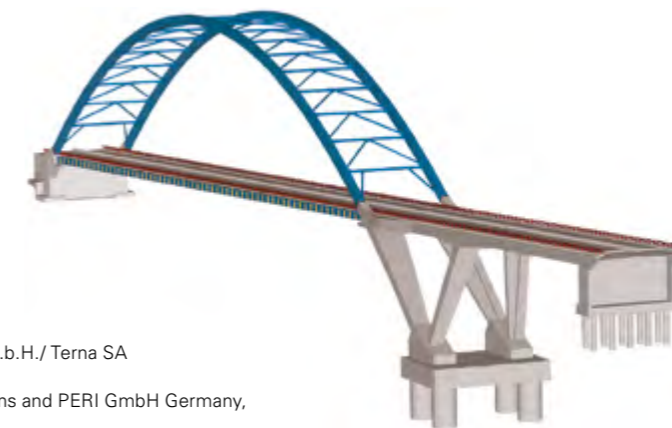

**Contractor**  
ARGE Alpine Bau G.m.b.H./ Terna SA  
**Field Service**  
PERI Hellas Ltd., Athens and PERI GmbH Germany,  
Weissenhorn Office

## Bridge over the Dunajec, Tarnow, Poland

### Fast and accurate through to bridge completion



**With some supplementary system components, the VARIOKIT engineering construction kit can also be used for the balanced cantilever construction method. For the construction of the motorway bridge near Tarnow, the construction crew achieved a 4 to 5-day cycle thanks to the easy to use, mechanical solution. At the same time, the high requirements concerning the very small tolerances for the variable bridge cross-sections could be fulfilled.**

The 600 m long motorway bridge is supported by twelve pairs of 13 m wide piers. The two parallel superstructures of the foreland bridges with hollow box cross-sections were realized on falsework – with the help of VARIO GT 24 formwork elements as well as ST 100 and MULTIPROP shoring towers. For the 210 m long section between the seventh and the tenth piers, the balanced cantilevered casting method proved to be the most cost-effective solution. A total of four cantilever construction units were used for constructing the bridge

superstructure in 48 casting segments respectively. Construction of the superstructure moved forward symmetrically in both directions from the starting point of two piers with 3.50 m to 5.00 m long sections until the gap was finally closed. The VARIOKIT cantilevered construction equipment demonstrated its great flexibility during the forming of the bridge cross-sections and, at the same time, was easy to operate. In particular, the moving procedure to the next concreting section each time was extremely user-friendly – by means of a hydraulic



**Karol Malinowski**  
Site Manager

“The PERI cantilevered construction solution offered us many advantages: rapid realization due to the well thought-out and simple operations as well as compliance with the required tolerances thanks to the practical formwork adjustment for precise construction of the webs. Furthermore, the compatibility with PERI UP ensures safe access points and working areas without any additional effort – indispensable for the execution of such projects.”

**Contractor**

Dragados S. A.

**Field Service**

PERI Poland Sp. z o.o., Krakow and Warsaw  
Offices, PERI GmbH, Weissenhorn

skidding system which is based on PERI self-climbing technology. Apart from the ease of use, the focus was very much on safety. The compatibility with the PERI UP modular scaffold was the basis for the creation of safe working areas with a minimum of effort for the construction team. Using standardized connection parts, PERI UP could be combined with the VARIOKIT components. The single-cell hollow box cross-section of the superstructure varies in height from around 2.50 m up to 6.10 m. The result was a continuous change in the angle between the outer side of the web and the cantilevers which meant the web formwork had to be re-adjusted for each concreting section. For this, PERI developed a simple and practical solution with variably fixable slab formwork and a formable steel sheet between the web and carriageway formwork. The construction team thus achieved extremely accurate results in accordance with the required low dimensional tolerances.

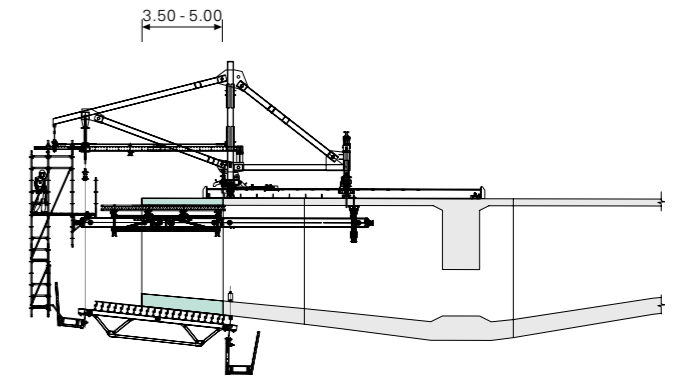

VARIOKIT and PERI UP could be ideally combined and provided safe working platforms and access.

The VARIOKIT engineering construction kit guaranteed maximum adaptability for the wide range of bridge cross-sections.

For moving to the next section by means of hydraulic drive cylinders, the construction team only required 2 hours.



## Waldschloesschen Bridge, Dresden, Germany

Elegant and economical crossing of the Elbe thanks to rentable system components



The name "Waldschloesschen Bridge" has not only been given to the bridge structure itself but also refers to the complete 4.5 km long traffic route which leads up to it. For the planning of the bridge height and geometry, a range of design aspects as well as ensuring an unimpeded view of the Dresden city centre were taken into consideration.

**The Waldschloesschen Bridge connects the eastern and southern districts of the city with areas in the north of Dresden. PERI planned and supplied the formwork for the superstructure of the steel composite bridge and won over the construction site team with an easy-to-use and, above all, cost-effective solution.**

The Waldschloesschen Bridge has a total length of around 635 m. Two steel arches with a span of 148 m reach of a height of almost 26 m above the Elbe and carry the central part of the bridge. The foreshore bridges account for a large part of the structure's length



In spite of the geometric changes found in the superstructure, only two standard raised formwork units were used which resulted in a very high degree of material utilization. On the VARIOKIT load-bearing system, GT 24 lattice girders provided support for the formlining.

with double V-shaped piers in place to support the superstructure.

The standard cross-section of the bridge in the arched area has an overall width of approx. 28 m. A 4-lane carriageway runs between the two steel arches whilst 4.45 m wide pedestrian and cycle lanes cantilever outwards on both sides of the bridge respectively. The formwork solution for the superstructure was developed by PERI engineers on the basis of the VARIOKIT engineering construction kit. Essential system components for the raised formwork construction suspended on the steel structure were SRU steel walers and SLS heavy-duty



The project-specific solution with lightweight raised formwork units ensured fast and simple moving to the next concreting section with the crane.

spindles. The mounting points for the formwork units were planned before the production of the steel structure. GT 24 wooden lattice girders transferred the loads into the formwork units and allowed large spans with minimal deflection. All system components used for the frame construction units were rentable.

In order to minimize deformations, a total of 21 casting segments were planned for the carriageway slab and cantilevers. The raised formwork units mounted on-site are thus being used for almost the entire bridge structure.



**Michael Wothe**  
Project Manager

"PERI provided us with the most logical concept for the superstructure formwork, specially tailored to match the specified bridge geometry. Already in the tendering phase, the formwork proposals were very detailed. The VARIOKIT sub-structure provided us with the ideal option to suit the local conditions. This could then be adapted to any site situation without any problems."

**Contractor**  
ARGE Ingenieurbau Waldschloesschenbrücke  
Sächsische Bau GmbH, Dresden  
and EUROVIA Beton GmbH, Oebisfelde  
**Field Service**  
PERI GmbH Germany, Chemnitz Office

## Third Bosphorus Bridge, Istanbul, Turkey

Highest bridge pier in the world formed with ACS



**The 1,408 m long suspension bridge across the Bosphorus is supported by two A-shaped reinforced concrete pylons – the highest in the world with a height of 326 m. The demanding geometries and complexity of the mounted parts required a very flexible planning process in the form of a complete solution.**

The 59 m wide Yavuz-Sultan-Selim-Bridge carries 8 lanes and two railway tracks with a span of 1,408 m across the Bosphorus, and connects – as part of the new North Marmara Motorway – the European and Asian continents. For the construction of the two pylons, efficient workflow processes as well as very high productivity and extremely short cycle times could be achieved with the ACS self-climbing system and VARIO GT 24 girder wall formwork. In addition, the high requirements in terms of flexibility, surface quality and dimensional accuracy were maintained throughout.



Construction of the upper area of the pylons was carried out in a total of 21 sections each with a 4.60 m concreting height. ACS V, the continuously adjustable version for all inclinations, could be optimally adapted to match the forward and reverse slopes of the side surfaces. For the almost vertically-positioned surfaces, forming was carried out using the standard ACS R version. The internal formwork was climbed with the help of the ACS V and ACS P platform variant. All ACS climbing units were provided with completely closed trapezoidal sheet cladding which provided anti-fall protection as well as additional wind and weather protection for site personnel in the lower levels. For the reinforcement work carried out in advance in the upper platforms, the perforated sheeting offered a high level of safety and let in daylight.

The triangular-shaped base structure with broken corners tapered constantly upwards. Over the height of the pylon, the 3 long polygon sides are reduced by 1.40 m respectively. Formwork adjustment took place using compensation plates and bolted filler elements which were gradually dismantled as required, while working platforms were adapted by means of centrally positioned filler platforms.

On the forward-inclined ACS platforms, a rotary distributor for concreting was climbed at the same time

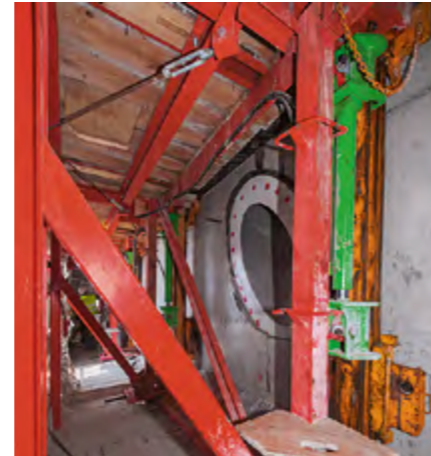

while access to the elevator was also integrated in the self-climbing system during the planning phase. In particular, for the assembly of the large-sized steel mounting components for the stay cable holding devices, the PERI solution offered the required flexibility. Any collisions with the stay cable boxes could be avoided whereby their dimensions and positions had already been taken into consideration when determining the climbing axes.

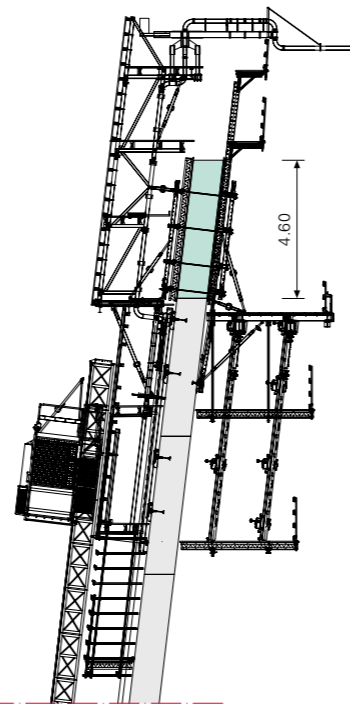

**Samet Seyhan,**  
Project Manager (ICA)  
**Evans Baek,**  
Deputy Project Manager  
(Hyundai/SK)

“The pylons are unique and extremely complicated due to the inclined conical shape and the numerous embedded items. The ACS system was the right decision for this type of bridge project because of the huge experience of PERI. Getting competent and comprehensive support to suit our tight schedule and providing completely safe working platforms at all levels and at any height were other positive aspects of PERI ACS system.”

**General Contractor**  
ICA – Consortium IC İçtaş / Astaldi  
**Contractor (Shell Construction)**  
Hyundai Engineering & Construction /  
SK Engineering & Construction J. V.  
**Field Service**  
PERI Kalıp ve İskeleleri San. ve Tic. Ltd.Şti Turkey,  
Istanbul and PERI Weissenhorn, Germany



## Brdjani Motorway Bridges, Čačak, Serbia

### Modular falsework variants on a system basis



Cost-effective: the PERI bridge formwork concept was based on rentable modular construction systems with standardized components.



VARIOKIT Engineering Construction Kit: the head spindles of the 4-legged VST Heavy-Duty Shoring Towers could also be operated when fully loaded by means of mobile hydraulics. In addition, the modular system allowed modifications to take place on the bridge piers as well as the use as 2-legged main beam frame.



#### Construction of the two Serbian bridges was realized with the help of modular construction systems. As falsework, PERI UP and VARIOKIT were used according to requirements.

The European Route E 763 was expanded as a motorway link between Belgrade and the border to Montenegro. For the new construction segment north of the central Serbian town of Čačak, two bridges were built within a short section: 232 m and 424 m long respectively, with individual spans ranging between 32 m and 42 m. Both structures have a 12.55 m wide and 2.20 m high superstructure with hollow box cross-sections which rest on massive reinforced concrete piers.

For the load-bearing system of the superstructure formwork, PERI Serbia combined two falsework variants. As supporting scaffold for the standard fields, PERI UP Framework Units were used. Here, load-optimized adjustment within the shear frames could be realized with bay widths of 50 cm, 75 cm and 150 cm. For the bridge sections in the area of the rivers, roads that were to be kept free along with ground of an insufficient load-bearing nature work was carried out with heavy-duty falsework. Here, VST Heavy-Duty Shoring Towers of the VARIOKIT Engineering Construction Kit transferred the high, concentrated loads into the ground.

All the customized formwork elements for the superstructure – as done previously for the bridge piers – were pre-assembled by PERI formwork assembly team at PERI Serbia's Simanovci facility near Belgrade and delivered ready-for-use to the bridge jobsite. This saved time-consuming assembly work on the construction site and ensured compliance with the extremely short construction schedule as well as a high quality of workmanship.

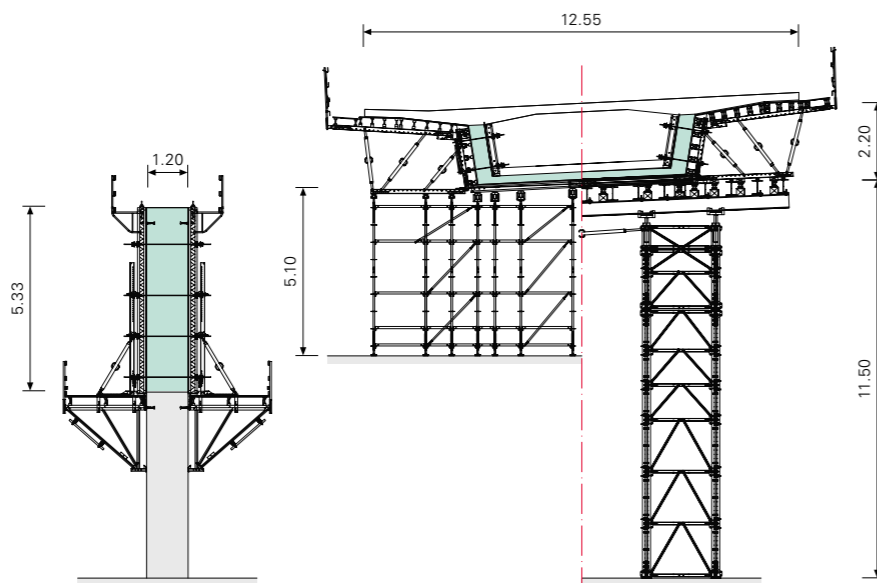

Construction of the reinforced concrete piers was carried out with CB/VARIO Climbing Formwork units. Adapted to meet the local conditions, the superstructure formwork was supported on PERI UP Framework Units and VARIOKIT Heavy-Duty Shoring Towers.



**Aleksandar Milenković**  
Site Manager

“PERI developed an excellent technical solution for our very challenging project. All systems used on the construction site were easy to use; in addition, PERI engineers provided us with regular and reliable on-site support.”

**Contractor**  
GP Planum AD, Belgrade  
**Field Service**  
PERI Oplate d.o.o., Šimanovci, Serbia



## Harpe Bru Bridge, Sør-Fron, Norway

VARIOKIT balanced cantilever solution  
optimized construction progress



**Contractor**  
JV Harpe Bru ANS  
Porr Infrastructure Polska; Implenja Norge AS  
**Field Service**  
PERI Poland Sp. z o.o., Plochocin z o. o.

The VARIOKIT balanced cantilever solution resulted in dimensional stability while the formwork facing with its board structure provided excellent concrete surfaces.

The combinability with PERI UP facilitated the realization of safe working areas along with access to all areas of operations.

**For the bridge superstructure, PERI civil engineering technology experts developed a balanced cantilevered solution based on the VARIOKIT System. The high degree of flexibility regarding the cross-section adaptation supported the rapid construction of the individual cantilever sections while simultaneously ensuring optimized workloads.**

The 320 m long cable-stayed bridge over the Gudbrandsdalen-Lågen in the Oppland province is part of the European Route E6 expansion project. The extradosed construction method, with the tendons positioned outside of the bridge cross-section, was used for the first time in Norway and allowed a low overall height of the superstructure and pylons. The span between the two

pylons is 100 m while two additional piers along with the abutments are positioned on the land.

The PERI solution for forming the 19.60 m wide superstructure consisted of 4 VARIOKIT Balanced Cantilever Carriages which were used to realize 5.55 m long segments in each case. In the process, the system was flexibly adapted to suit the geometric cross-sectional changes and the varying, in part, very high loads with constantly load conditions. In particular, the planning took into account the cable arrangement of the segment suspensions in order to prevent collisions with the balanced cantilever equipment. In addition, 1.30 m high transverse ribs were realized together with the bottom slab and side walls of the

hollow box girders. The carriageway slab was subsequently concreted in a second casting segment.

VARIOKIT minimized the required workload for each bridge section. For example, the independent moving procedure by means of the integrated hydraulics along with fully hydraulically-operable aligning and adjusting led to optimized cycle times. Furthermore, the detailed implementation plans and technical documentation ensured on-site formworking operations could be easily and efficiently carried out. The high proportion of system components from the VARIOKIT Engineering Construction Kit as well as the high availability of materials in the PERI rental park ensured a high level of cost-effectiveness.

A total of 4 VARIOKIT Balanced Cantilever Carriages ensured rapid construction progress with work taking place on the final gap closure in December, 2015.

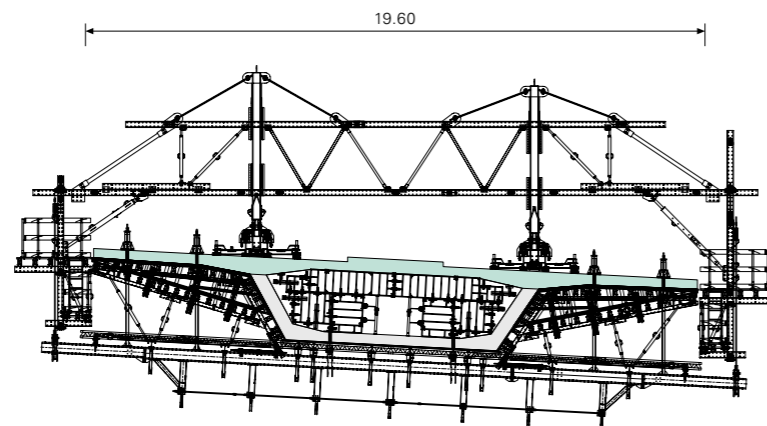

**Mariusz Urbanski**  
Construction Manager

“The chosen solution of using VCB Balanced Cantilevered Carriages proved itself to be correct. Thanks to the high flexibility of the system, we could optimize our project so that the workload necessary to pour each segment was as short as possible. It also had a measurable influence on the assumed schedule.”



## Chamiza Viaduct, Puerto Montt, Chile

Load-bearing system combination for massive pier heads



**Ideally matched systems form the basis for efficient and cost-effective construction operations. In particular for the realization of Chamiza bridge piers complete with massive pier heads up to 40 m high, PERI Chile provided materials and know-how from a single source. The complete solution for formwork, supporting structure and access technology was based largely on standardized system components.**

The Chamiza Viaduct is an important section which connects Route 7 (Carretera Austral) in the south of Chile near Puerto Montt to the well-known Pan-American Highway, Route 5. Together, both highways form a 4,700 km stretch of road from the Peruvian border in the north almost all the way to Tierra del Fuego.

Nine, up to 40 m high piers support the 410 m long bridge over a valley floor. For constructing the double piers with hollow box cross-sections, VARIO GT 24 Girder Wall Formwork and

CB Climbing Platforms were combined to create craneable moving units. This ensured – also in connection with successively height-extended PERI UP Stair Access – fast and safe work processes from the beginning onwards.

The 4.00 m deep and up to 2.20 m high pier heads widen to more than 23 metres. For this, PERI engineers designed an extended cantilevered bracket solution to form a stable contact area and high load-bearing surface for the formwork on the basis of the VARIOKIT Modular Construction

System. With the help of VARIOKIT system components, the loads between the double piers could also be reliably transferred. Construction time was accelerated in particular by the fact that complete units were assembled on the ground which could then be lifted by crane into the intended position.



Customized system combination: above the VARIOKIT construction, PERI UP served as a shape-providing load-bearing system. TRIO Panel Formwork was used as side formwork while PROKIT Side Mesh Barriers mounted end-to-end provided a high level of safety when working at great heights.

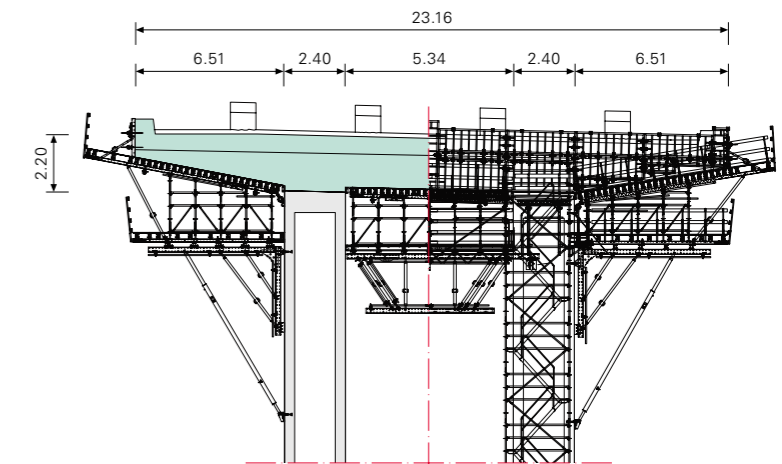

#### Contractor

Consorcio Viaducto Chamiza S.A.:  
Besalco Construcciones S.A.;  
Arrigoni Montajes

#### Field Service

PERI Chile Ltda., Santiago de Chile



**Carlos Rauch**  
Senior Project Manager

“For this unprecedented bridge project, with PERI we found a partner with the corresponding experience and technical support. For us, the formwork solution was perfect in all respects – it provided our site personnel with a high level of safety, was easy to install as well as being cost-effective. This positive experience can – and also due to the added value through competent on-site support and high product Quality – hardly be beaten.”

## Lanaye Lock Bridge, Belgium

Individual project solution with a construction kit system



The 136 m long main crossing was constructed with the help of two VARIOKIT Steel Composite Formwork Carriages using the alternate sequential method within the planned time frame.

The VARIOKIT Formwork Carriage could be flexibly adapted to match the geometrical and static requirements which included 4.50 m cantilevers.

Both construction variants – formwork carriage and cantilevered brackets – were based on the VARIOKIT Engineering Construction Kit.



**For constructing the steel composite bridge, PERI engineers adapted the VARIOKIT System solution – formwork carriage and cantilevered brackets – to match the wide range of construction site requirements.**

The new 200 m long road bridge crosses the navigation channels of the newly expanded border lock facility between Belgium and the Netherlands at right angles. The S-shaped, 15 m wide bridge structure was realized using the steel composite construction method. With the help of two independently-operating VARIOKIT Composite Formwork Carriages, the 136 m long main crossing was constructed using the alternate sequential method within the ambitious time frame – in 13 casting segments with cycle lengths of 8 m to 12 m.

The Formwork Carriages could be individually adapted to suit the geo-metrical and static requirements; this was particularly important as the bridge features an unusually large cantilever length of 4.50 m. In the area of the two bend radii – extremely tight at just

30 m – the PERI bridge solution integrated the use of VARIOKIT Cantilever Brackets. In the geometrically and statically complex area of the circular columns, the brackets were arranged radially. Pressure supports transferred the concentrated loads of the external cantilevers into the available bridge piers. For this, system components from the VARIOKIT Engineering Construction Kit were complemented by MULTIPROP 625 Aluminum Slab Props to form the PERI complete solution.

Apart from the use of standardized system components, pre-assembled formwork units delivered to the construction site accelerated the final assembly and ensured rapid and problem-free construction site use from the outset. The dimensionally-accurate fabrication took place at the PERI formwork assembly facilities in Weissenhorn and Düsseldorf. In addition, the site management was provided with ongoing support by Belgian and German PERI engineers from the beginning onwards.



**Pedro Da Guia**  
Technical Director

“Due to our positive experience with similar projects, we decided once again in favour of PERI. Their technical support within the framework of the tight schedule as well as the project solution using the formwork carriage and cantilever brackets have confirmed our decision.”

**Contractor**  
BESIX Wallonia-Luxembourg, Brussels  
**Field Service**  
PERI NV Belgium/Luxembourg, Londerzeel  
and PERI GmbH Germany, Weissenhorn  
and Düsseldorf

The expansion of the Lanaye lock facility required the new construction of a 200 m long road bridge complete with two 90° bends on the river banks.



## Mur Bridge S 35, Frohnleiten, Austria

Large span with low weight and high load-bearing capacity



**Heimo Egger**  
Assembly Supervisor

“The VARIOKIT heavy-duty truss system with the variable starting frame has set new standards in shoring operations. It reduces the amount of assembly work required especially for inclined supporting structures. The accuracy of fit as well as aligning the pairs of trusses also make a convincing case.”

**For the construction of the Mur Bridge, the modular VARIOKIT Heavy-Duty Truss stood out through its extremely high load-bearing capacity with a comparably low weight. In addition, the system components could be quickly installed and had a very flexible use.**

The altogether 406 m long new bridge construction near Frohnleiten is the centrepiece of the S 35 motorway modernization project between the Bruck/Mur and Graz intersections.

The new structure completely replaced the existing 60-year-old bridge which runs alongside. The pre-stressed concrete superstructure was designed as a 11.75 m wide T-beam cross-section complete with 2.50 m web heights.

In spite of every respective 40 m spans of the two main bridge sections over the Mur, the construction of the superstructure on heavy-duty falsework by means of framework units was the most cost-effective solution. For this, a German-Austrian team of PERI engineers designed a customised project solution on the basis of standardized, rentable system components from the

VARIOKIT Engineering Construction Kit. The truss arrangement were flexibly determined in accordance with static requirements and featured truss spacings of 50 cm and 150 cm.

In addition to the benefits of the project-specific planning and verifiable static calculations, the rapid availability of materials along with the briefing of scaffold erectors on-site by a PERI supervisor ensured short assembly times from the beginning onwards. In spite of the difficult boundary conditions – assembly and storage areas were extremely limited – this still allowed the construction schedule to be maintained. The lifting of the more than 37 m long coupled trusses by means of a mobile crane parallel to the existing bridge also required an experienced assembly team and perfectly coordinated working steps. A big advantage here was the low weight of the VARIOKIT Heavy-Duty Truss. This resulted in time and cost savings especially during the lifting procedure.

Modular shoring assembly with standardized connections and a minimum of tool usage: VARIOKIT system components were pre-assembled on the ground to form truss segments, placed in intermediate storage, and subsequently coupled to create 37 m long truss units.

**Contractor**  
Bidding Consortium Strabag/Habau  
**Scaffolding Contractor**  
XERVON Austria GmbH, Maria Lanzendorf  
**Field Service**  
PERI Austria, Nußdorf  
and PERI Germany, Weissenhorn

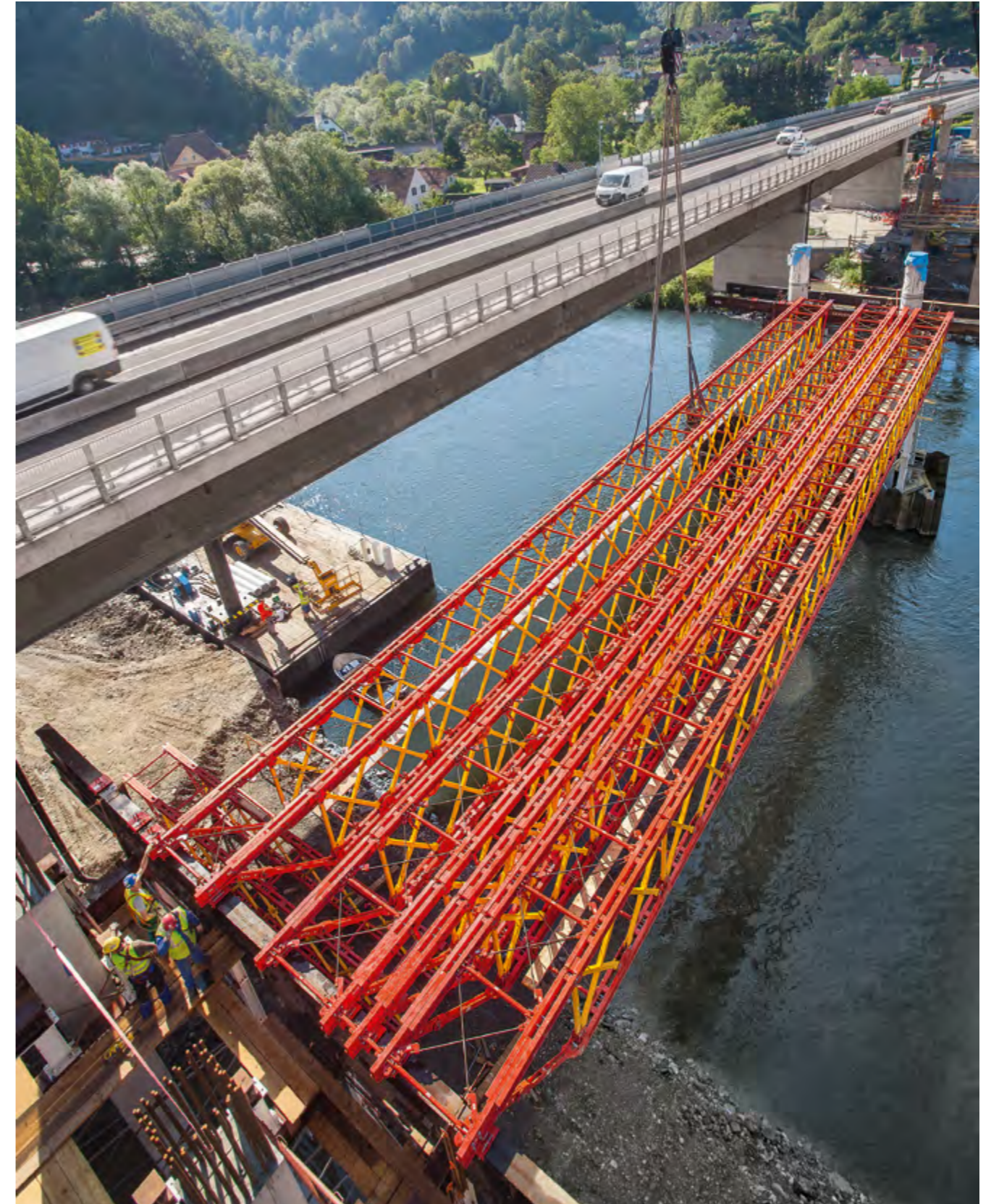

# Ohio River Bridge “East End Crossing”, Louisville, USA

## Climbing formwork and shoring solution for complex pylons



Heavy-Duty Shoring Towers and Truss Girders from the VARIOKIT Engineering Construction Kit provided a solid basis for forming the cross beams at the level of the road surfaces.



Continuous construction support and a competent planning service: the catwalk featured between the two pylon legs was also an integral part of the PERI complete solution.

**Contractor**  
Walsh/Vinci Construction  
**Field Service**  
PERI Formwork Systems Inc., Chicago, USA, and  
PERI Germany, Weissenhorn

**Perfectly matched formwork, climbing, shoring and scaffolding systems ensured rapid construction of two bridge pylons with their complex shapes – within the specified construction period as well as dimensional tolerances.**

The 762 m long cable-stayed bridge over the Ohio River connects the states of Kentucky and Indiana. The new bridge is part of the nearly 14 km long road construction project which is designed re-route the Interstate 64 to the north of Louisville.

The span of the main bridge section reaches 365 m, and the carriageway is carried by means of stay cables supported by two reinforced concrete pylons, each 90 m high. The lower, outwardly-inclined pylon legs are solidly constructed while in the upper segment, the pylon legs are inclined inwards and feature hollow box cross-sections. The cross-sections taper in an upwards direction, and a slight curvature causes a continuous change in the angle of inclination from casting segment to casting segment. Two 3.65 m thick cross beams – one at road surface level and the other at the upper pylon reinforcement – were also realized using in-situ concreting operations.

From the bottom to the very top, each construction phase presented a particular challenge in terms of geometry and load transfer. For this, a German-American PERI project team developed and delivered a complete solution – on the basis of several formwork and scaffolding systems taken from the extensive PERI rental pool. VARIO GT 24, ACS and RCS Self-Climbing Formwork, the single-sided SCS Climbing System, VARIOKIT Shoring and the PERI UP Scaffolding Kit could be perfectly matched to one another – and ensured fast cycle sequences, high load-bearing capacities and a maximum level of safety during all stages of construction.

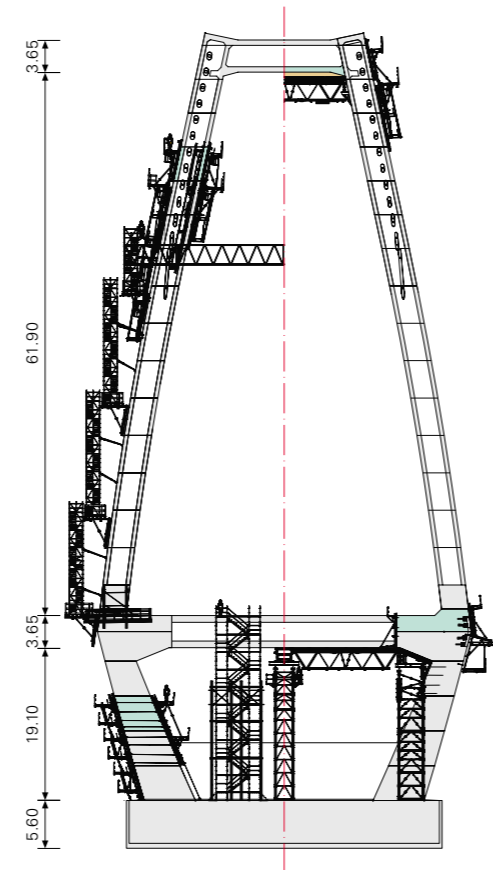

**Mike LaSalle**  
Senior Project Superintendent

“The ACS Self-Climbing System and heavyduty VARIO formwork have allowed us to meet the project’s tight tolerances and schedule demands. PERI’s extensive site service and engineering support have aided us in tackling the many project complexities.”



## Motorway bridge over the River Drava, Osijek, Croatia

### Formwork solution for pylons and superstructure



RCS, CB and VARIO GT 24 formed the ideal climbing combination for constructing the two bridge pylons.



The new 2,500 m long bridge carries the A5 motorway across the River Drava in east Croatia.



The foreland bridges are supported on 180 cm thick circular columns – here, too, PERI supplied a customized formwork solution.



**Ante Sabljic, and  
Anto Vranjkovic,  
Site Manager Pylons and  
Site Manager Superstructure**

“The VARIOKIT solution perfectly combines functionality, flexibility, reliability and faster assembly. As a result, we could optimally fulfil all technical requirements of the project. As usual, the PERI solution took into account all required details. In addition, the climbing formwork solution is not only very cost-effective but it also allows very short cycle times. The PERI technology used is very practical and we could also achieve a high standard of safety. We would also like to praise the support given to our construction team by PERI engineers before and during construction operations.”

**As a competent partner, PERI provided customized solutions for constructing the pylons, superstructure and pylons – adapted to meet a very wide range of requirements.**

The A5 motorway bridge which spans the River Drava, is altogether 2,500 m long. Two 75 m high A-shaped pylons carry the three main sections of the cable-stayed bridge with 220 m and 100 m spans respectively. The approx. 1,000 m long foreshore bridges on both sides are located in the flooding areas, and were realized using pre-stressed prefabricated beams on massive circular columns.

The rectangular cross-section of the pylons is constantly changing – from 6.50 m x 3.50 m in the base area up to 4.00 m x 5.00 m below the converging pylon head. For the realization of this complex geometry, PERI engineers combined the CB and RCS Climbing Systems. On the front sides, the CB 240 Platforms together with the

VARIO GT 24 Girder Wall Formwork were moved with the crane. For the up to 18° forward and reversed-inclined outer surfaces of the pylon legs, the rail-guided RCS Climbing Formwork provided the optimal solution whereby the units could be continuously climbed regardless of the weather and without requiring a crane by means of mobile hydraulic pumps. As a result, each of the 24 concreting sections could be completed within an average of 5 days.

The PERI solution for constructing the parapets of both carriage ways was based on the VARIOKIT Engineering Construction Kit. The VARIOKIT Parapet Carriage was used for constructing the external, large-sized parapets. As the loads were transferred via a gallows construction, anchoring in the superstructure was not required. For forming the parapets on the inner sides of the carriageways, VARIOKIT System Components were combined with the PERI UP Modular Scaffolding.

By means of simple rollers, the formwork and supporting construction could be quickly moved as one unit to the next concreting section.



#### Contractor

Skladgradnja d.o.o. Split (Superstructure and foreland bridges)

Viadukt d.d. Zagreb (pylons)

#### Field Service

PERI oplate i skele d.o.o. Hrvatska, Zagreb

## Ayalon Highway Bridge, Ga'ash/Shefayim, Israel

Modular bridge construction solution with short moving times



**For routing the highway over a railway line, PERI's Israeli engineers ideally matched the superstructure formwork with the shoring. The fast assembly and fast cycle sequences saved working time and accelerated the construction progress.**

The Ayalon Highway (20) is the main traffic artery of the region in and around Tel Aviv. It is being extended to the north and, at Shefayim, it joins Highway No. 2 which heads in the direction of Haifa running parallel to the Mediterranean coast. For crossing a railway line, the construction of a 450 m long bridge was required.

The 15.60 m wide superstructure of the 12-section bridge was constructed with T-beam cross-sections using in-situ concreting operations. Webs and plates could be concreted in one pour with the help of PERI bridge formwork – without requiring any additional horizontal anchoring through the webs. VARIOKIT raised formwork units were positioned on supporting scaffold based on the PERI UP Modular Scaffold system. For this, 1.50 m wide and 15.75 m long framework units were formed while load-optimized adjustments were carried out by integrating 150 cm and 75 cm field widths. For realizing the construction in only 4 cycles, the concreting cycle lengths were each 115 m.

The special feature of the PERI solution was that the generously-dimensioned formwork units could be fixed to the bridge superstructure by means of DW 15 tie rods after concreting and curing had taken place. As a result, the relieved PERI UP supporting structure could be quickly moved to the next cycle each time. The formwork units were subsequently lowered using winches and could likewise be transported to the next phase of construction without requiring any time-consuming dismantling work.



**Rem Nahshon**  
Project Manager

“Building a bridge reveals many challenges along the way. PERI was the best partner for that matter, being focused on our requirements with innovative design and ideas, on-site support and excellent equipment: PERI UP as ‘stand-alone’ shoring and VARIOKIT as stiff formwork units.”

**Contractor**  
T.O.N. Infrastructure Works Ltd.  
**Field Service**  
PERI F.E. Ltd., Rosh Ha'ayin, Israel

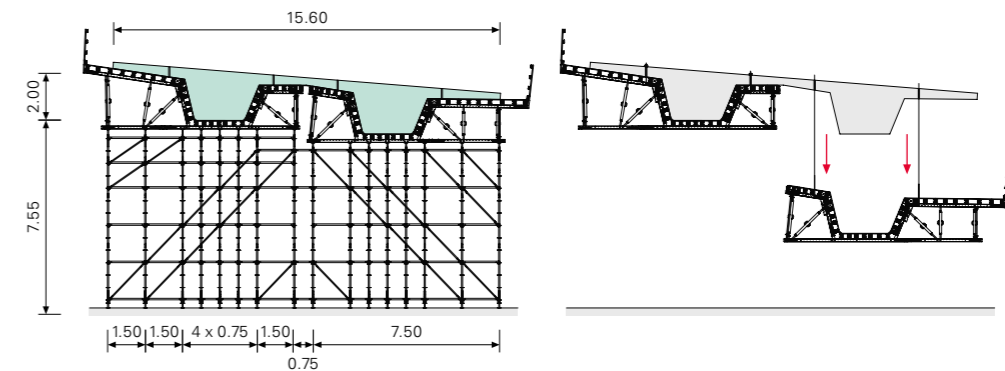

The two modular construction systems, PERI UP and VARIOKIT, could be flexibly adapted to suit the bridge geometry and loads.



The approx. 8m x 3m generously-dimensioned formwork units on the basis of the VARIOKIT Engineering Construction Kit could be moved using only one crane lift thus saving time.



The PERI formwork and shoring solution as well as the continuous on-site support accelerated the construction work on the 450 m long motorway bridge (Building Structure 301).

## Krakow-Plaszow railway junction crossing, Krakow

Cost-effective cable stay bridge construction with VARIOKIT balanced cantilever equipment



The current expansion of the Krakow metropolitan railway network (KST) requires, among other things, crossing of the Krakow-Plaszow railway junction. Ensuring that daily rail operations remained unaffected during the construction of the 252 m long crossing was a prerequisite which meant the general contractor decided in favour of the cantilevered construction method for realizing the extradosed bridge with its hollow box cross-section. In addition, the compatibility with the PERI UP modular scaffolding provided safe working platforms and access

means to all working areas. Through the customized solution devised by PERI engineers, the construction team have been able to realize each 5.70 m long concreting section using 4 VARIOKIT cantilevered construction carriages. Thanks to the high degree of flexibility and easy alignment of the system, complicated pre-tensioning sequences have been implemented in the longitudinal and transverse directions of the viaduct. Among other things, the tendons as well as the anchorage points of the stay cables outside of the box girders had to be

taken into account. Furthermore, carrying out construction work during daily train operations along with the allocated downtimes has complicated the ongoing completion of the cantilever above the tracks. Nevertheless, the respective segments can be constructed without any interruptions in 2-week cycles.

After closing the respective gap of the bridge span, the PERI VBC balanced cantilevered carriage automatically returns to its starting position although cable stays are positioned along the



**Artur Salachna**  
Foreman  
**Krzysztof Goliński**  
Bridge Construction Manager

“The PERI cantilevered construction equipment used allowed easy and quick formwork alignment as well as providing safe working conditions above the railway. With the help of the balanced cantilever carriage, extremely short concreting cycles as well as punctual realization of the project according to plan are possible. Thanks to the cooperation with PERI, the job could be realized in spite of the complicated infrastructure around the structure.”

structural axis. As a result, dismantling the equipment is always efficient and safe.

PERI Poland took on the customized project planning and static calculations of the comprehensive solutions for the superstructure on PERI UP falsework as well as the cantilevered construction. All systems and processes were therefore optimally matched and allowed on-time completion according to plan. Through the close cooperation between the general contractor, planners and PERI engineers, the shape of the reinforcing ribs along the bridge

superstructure, among other things, could be optimized during the planning phase in order to accelerate the execution times. The biggest challenge when realizing the formwork planning proved to be dealing with the significantly asymmetric shape of the superstructure cross-section as well as its varying width along the structural axis.

### Safety during on-going daily train operations

The compatibility of the cantilevered construction carriage with the PERI UP modular scaffolding has allowed, as part of the comprehensive PERI project

solution, the creation of safe working areas. With a minimum of effort for the construction team, the scaffold could be connected to the VARIOKIT standard components by means of easy-to-use connecting devices in order to provide safe working platforms and access.

### The VARIOKIT balanced cantilever equipment

The PERI VARIOKIT With optimized components of the cantilevered construction carriage, up to 5.75 m long segments can be concreted. In addition, VARIOKIT system components are used. As a result, PERI achieves maximum adaptability for different bridge cross-sections.

The integrated, centrally-controlled mechanism with hydraulic cylinders as well as lifting and powering devices for moving, lowering and raising the carriage and formwork guarantees easy handling of the balanced cantilever equipment. The hydraulics also simplify the adjustment and levelling of the formwork from section to section.

All cantilevered construction carriage modules can be used again in future projects. In addition, virtually all the components are available from the PERI rental park. This not only ensures fast availability of all parts but it also increases the cost-effectiveness of the solutions for the construction company.



**General Contractor**  
Mota-Engil Central Europe S.A.  
**Field Service**  
PERI Poland – Krakow Office,  
Kattowitz Office

## Williams Bridge, Rotterdam

System combination for challenging pylon scaffolding



Overnight, the 21 m long, pre-assembled VARIOKIT Truss Girder units were lifted and coupled to VST Shoring Towers using a mobile crane.



Designed to accommodate the high loads, the scaffold anchoring and bracing was also realized with VARIOKIT system components.



Situated in the centre of the Dutch metropolis Rotterdam, the Williams Bridge is one of the most important road connections between the northern and southern parts of the city. The striking cable-stayed bridge over the River Maas with its two red, 60 m high steel pylons had to be renovated which involved sand-blasting and repainting operations. The pylon refurbishment was carried out by the Venko company while Steigerbouw Van der Panne was responsible for the scaffolding work.

One of the special project features was that all scaffolding and painting work had to be carried out without any major negative impact on the flow of traffic through the city. As the entire superstructure is only freely suspended by means of the stay cables, it was also not possible to set up the approx. 200 t scaffold construction for each respective pylon on the carriageway slab.

Together with the scaffolding specialists from Steigerbouw Van der Panne, PERI engineers designed an overall solution that was optimally adapted to fully meet the project requirements,



**Marcel Broekman**  
Project Manager

"Mounted overnight and laterally positioned on the concrete base, the VARIOKIT bridging made it possible to erect the 60 m high and 200 t PERI UP scaffolding construction without loading the carriageway and negatively affecting the flow of traffic. In short, we are extremely satisfied with both the PERI systems and the collaboration."

and which was based on two combinable modular systems.

The PERI UP Flex Modular Scaffolding System provided flexible adaptation possibilities to match the pylon geometry thus ensuring safe working levels including access technology. A combination comprising VRB Truss Girders and VST Heavy-Duty Shoring Towers taken from the VARIOKIT Engineering Construction Kit carried the high loads across the entire width of the carriageway which were then laterally transferred via the pylon foundations.

On the basis of the detailed joint preliminary planning along with the possibility of seamlessly integrating VARIOKIT into the PERI UP scaffolding solution, only one night was required for assembling the truss girders for bridging the carriageway of the structure. The girder package was pre-assembled with each girder having a length of 21 m, and then transported to the site on a heavy-duty truck. On reaching their destination, these units were quickly lifted by a mobile crane onto the VST Heavy-Duty Towers positioned on the sides and coupled by means of bolts.

During the work, unrestricted use of the bridge was to be ensured.



**Contractor**  
Steigerbouw Van der Panne, Rotterdam  
**Field Service**  
PERI Schijndel, Netherlands,  
and PERI Weissenhorn, Germany

## Immensitz Bridge A81, Geisingen, Germany

Quick and simple: 10 m cantilevered parapet daily

The outer and middle parapets of the Immensitz Bridge were realized using two VARIOKIT Cantilevered Parapet Tracks.



During the bridge construction work, traffic on the A 81 motorway could use the already completed superstructure situated between the Geisingen and Engen junctions.



The VARIOKIT Parapet Track was suspended by means of rails and roller units from the underside of the bridge cantilever - at an identical position to the moving procedure and concreting.



Due to the low operation effort, the units could be moved quickly by means of an integrated winch.

**The outer and inner parapets of the Immensitz Bridge were realized with the help of two VARIOKIT Cantilevered Parapet Tracks. Thanks to the simple handling and movability of the PERI system, the construction team was able to complete on average a 10 metre length of parapet every day.**

The 227 m long Immensitz Bridge guides the A 81 motorway between the Geisingen and Engen junctions at a height of 25 m over the L191 secondary road. The bridge superstructure was built 1971 and needed to be refurbished. The initial phase saw the North Bridge being demolished and a new steel composite construction erected on the

existing bridge piers and abutments. This was followed by the realization of the southern superstructure during which traffic was guided over the completed new structure through to the end of the construction project.

For the construction of both cantilevered parapets on the southern bridge structure, the PERI team planned two Parapet Tracks on the basis of the VARIOKIT Engineering Construction Kit. As a result, 60 m to 80 m parapet lengths – with section lengths of 20 m respectively - were formed, reinforced and concreted every week. PERI engineers adapted the formwork and platform dimensions according to project specifications to suit the local

conditions thereby taking into account the different positions of the lateral bracing of the bridge superstructure. In addition, due to the statically optimized arrangement of the anchoring points, the number of mounting parts in the superstructure could be considerably reduced thus saving costs.

Due to the anchoring of the parapet track to the underside of the bridge and the low structural height of the VARIOKIT formwork solution, the parapet to be formed was freely accessible at all times. This created almost unrestricted construction options for subsequent trades activities.



**Mike Schmiedel**  
Site Manager

"Due to the simple handling in the construction process and the high level of expertise and personal competence of the PERI engineers, we used the PERI Cantilevered Parapet Track on our jobsite. Their solution could be realized exactly in accordance with the preliminary planning – without any restrictions for subsequent trades activities."

**Contractor**  
Hochtief Infrastructure GmbH, Deutschland Ost  
Office  
**Field Service**  
Infrastructure Competence Centre, Weissenhorn/  
Günzburg

## Mersey Gateway Bridge, Runcorn to Widnes, Great Britain

PERI helping to shape the Mersey Gateway Bridge



A PERI project manager provided on-site support and ensured efficient execution of the planned formwork and scaffolding solution. The PERI planning also took cost-effective use of materials into account: the SB Brace Frames were used for the bracket-type pylon widenings as well as the pier heads of the approach bridges.

**Through the construction of the Mersey Gateway, Merseyside in the north-west of England expects a significant improvement in its transportation system. More than 2 km long, the road bridge over the River Mersey is an integral component of the new A533 Central Expressway and – 20 km east of Liverpool – an important traffic connection between the town of Runcorn in the south and Widnes in the north.**

Three pylons carry the bridge superstructure with a total of 6 lanes over a length of around 1,000 m across the River Mersey. Engineers from PERI Great Britain supported the construction of the massive pylons with their

profound bridge-building expertise as well as project-specific formwork and climbing technology. In addition, the continuous site support provided by a PERI project manager ensured trouble-free implementation of the challenging construction project. For the 3 pylons of the cable-stayed bridge with a height of 125 m in the south, 80 m in the centre of the bridge and 110 m in the north, PERI engineers planned the use of ACS Self-Climbing Formwork. The solution made it possible to work crane-independently as the ACS 100 climbing hydraulics safely carried the formwork and working platforms as one unit up to the next section. On the one hand, this saved on valuable crane capacities while, on the other, it was possible to climb even in strong winds.

A major challenge when constructing the pylons was the complex shape featuring bracket-type widenings across the supporting carriageway which serve to support the superstructure. Thus, the highest of the three pylons extends from 6 m to a total of 17.50 m at a height of 20 m. For this area, PERI's British engineers designed a concept on the basis of horizontally-mounted SB Brace Frame units which could be coupled together. This resulted in generously-sized working platforms with widths up to 7 m. At the same time, the brace frames reliably transferred the loads of the cantilevered concreting sections into the pylon shaft.



**C H Lee**  
Technical Director

"The PERI ACS Self-Climbing System in connection with the retractable formwork and PERI UP Scaffolding served as quick and easy formwork for the pylon construction and safe access throughout. This solution accelerated the concreting work and shortened the cycle times so that we could climb 5 m high sections every 5 days."

#### Contractor

Merseylink Joint Venture:: FCC Construcción S.A.; Kier Infrastructure & Overseas Ltd.; Samsung C&T Corp.

#### Field Service

PERI Great Britain

## Hammecke A46 Motorway Viaduct, Bestwig, Germany

### Mobile system combination

**The 650 m long Hammecke Viaduct is part of the A46 motorway between Bestwig and Nuttlar. The 5.6 km long road section provides improved accessibility to the Sauerland region and simultaneously relieves the existing Bestwig through-road.**

The construction site team of Adam Hörnig GmbH used two mobile suspended scaffolds from PERI for subsequent reworking operations on the new bridge. This allowed the team to carry out finishing work on the 1,300 m long cantilever of the bridge superstructure as well as the support areas within the specified time frame.

A decisive advantage of the PERI solution was the possibility to combine the VARIOKIT Engineering Construction Kit with the PERI UP Flex Modular Scaffolding System. On this basis, PERI engineers together with the project managers from Adam Hörnig designed an optimized project-specific construction site solution. Due to the standardized system components and connections, the construction personnel could quickly mount the two suspended scaffolds on site. Moving from the south to the north side of the bridge was also problem-free thanks to the low overall weight and the possibility to shift the scaffolding units segment by segment.

The suspended and up to 5 m long cantilevered working platforms were designed so that the complete underside of the bridge in the cantilevered area was easily accessible for all work operations. An integrated stair tower ensured fast and convenient accessibility to the different working levels.

The PERI solution also took into account the variable superstructure geometry. Including ballast, each of the 3 m long scaffolding units weighed only 4 tonnes thus allowing them to be moved quickly and easily in the longitudinal direction using conventional construction equipment.



**Alexander Ehrlich**  
Site Manager

"The most convincing thing I found was the simple moving procedure to the other side of the superstructure. Through loosening only a few connecting parts, we could move the upper and lower parts segment by segment. Thereby, and thanks to the overall low dead weight, only a small mobile crane was required and the movability was enhanced as well."



The suspended and up to 5 m cantilevered working platforms were designed so that the complete underside of the bridge in the cantilevered area was accessible.



Including ballast, each unit weighed only 4 t, allowing it to be moved quickly and easily in the longitudinal direction using conventional construction equipment.

**Contractor**  
Adam Hörnig Baugesellschaft mbH & Co. KG, NL  
Thüringen  
**Field Service**  
PERI Frankfurt, PERI Weissenhorn



## Innbridge at Terfens, Terfens, Austria

### Optimised processes thanks to new PERI system

**The reconstruction project of the Innbridge at Terfens in an earthquake zone on the A12 motorway was one of the largest bridge construction projects to be carried out in western Austria. With PERI by their side, the construction site team was able to complete the project on time despite the demanding construction schedule, and with the necessary structural calculations for earthquake loads.**

By using the VBC Balanced Cantilever Carriage including formwork, PERI provided the client with a comprehensive solution, not to mention planning services and on-site support. The decision to use the VBC Balanced Cantilever Carriage meant that 5.70 m long concreting sections could be realised. This meant that the number of construction phases could be reduced to only four per bridge support structure. The fact that the system is highly flexible and easy to align meant that the respective segments could be concreted in weekly cycles, the projection of

the cross girders in the grate could be adapted, and the supporting structure had a spacing of only 50 cm. The latter was necessary due to the longitudinal cantilevered slab retaining wall in the abutment area, which extended from the upper edge of the foundation to the lower edge of the cantilevered slab. What's more, the fully integrated hydraulics simplified the process of adjusting and calibrating the formwork from one section to the next. Given the fact it is convenient to operate, the system could be moved to the next cycle quickly and easily.

The formwork carriage also proved to be advantageous during the concreting process as its carriageway slab formwork reduced the degree of penetration in the supporting structure due to the fact it is positioned on the M24 anchor sleeves. The balanced cantilever carriage was also straightforward to dismantle – the time-consuming process of lowering the rails to retract the carriages was not required.

#### Contractor

ARGE (PORR/Strabag), Zirl, Austria

#### Field service

PERI Austria, Reichersdorf



**Bernahrd Ramsauer**  
Site Manager

“The fact that we had to take the River Inn’s high-water periods into account meant that the schedule was very demanding. We were able to reduce the number of construction phases on each supporting structure by two due to the fact that we were able to concrete 5.70 m section lengths with the PERI VARIOKIT VBC system. Furthermore, when we were awarding the contract, particular emphasis was placed on a straightforward procedure for retracting the scaffolding and on the technical details regarding the ability to adapt to the spatial limitations posed by the old existing bridge when erecting the first supporting structure and by the new bridge when erecting the second supporting structure.”



© Günther Bayerl



© Günther Bayerl



© Günther Bayerl

## Čortanovci viaduct, Novi Sad, Serbia

Easily adaptable: PERI systems ensure swift construction progress

**The Budapest-Belgrade high-speed line is part of the Budapest-Belgrade-Skopje-Athens international rail link. One of the bigger challenges on this route was the Čortanovci viaduct, which is located between Stara Pazova and Novi Sad. PERI assisted with the construction of sections B and C, each 642 m long.**

The concreting work for both sections B and C was carried out simultaneously to the left and right, starting from the delta pier in the middle. The 18.50 m high delta pier was therefore initially realised per carriageway in both sections. The construction workers found support in a combination of the PERI UP system and components from the VARIOKIT Engineering Construction Kit. As both systems are based on the modular principle as well as on a metric basic grid, any adjustments required to geometries and loads could be made in 25-cm-increments. The optimum connection options ensured that the formwork and scaffolding solution was perfectly coordinated and available from a single source. For the rest of the columns required for both stages, CB Climbing Units were used as safe working platforms to support the TRIO Panel Formwork as well as the VARIO GT 24 Girder Wall Formwork.

To transfer the loads in section B, the decision was made to use the ALPHAKIT Shoring Construction Kit, which is suitable for particularly large support heights. The assembly of the 24.75 m high towers was particularly efficient due to the small number of lightweight single components. The pre-assembly process was carried out quickly and safely from the ground. The ability to position and move the units by crane thereafter meant that time was saved and construction progressed quickly. Moreover, additional working platforms from the PERI UP Scaffolding Kit were installed to provide a greater level of safety for the construction site personnel at great heights.

Throughout the entire project, PERI engineers were on hand to assist the construction site personnel. On account of the intensive amount of material planning work carried out in advance, as well as the supportive and advisory supervision provided while the systems were being installed, adhering to the tight construction schedule was no issue at all.



**Boris Miloradov**  
Chief Engineer

“Thanks to the close cooperation between the companies Karin Komerac and PERI, this magnificent railway bridge, which is unparalleled in our region, was completed within the deadlines set. We are particularly grateful for the assistance provided by the engineering team consisting of PERI planners and site managers, without whom we would not have been able to carry out the work on the viaduct so quickly and successfully.”

**Main contractor**  
RZD International, Belgrade, Serbia  
Subcontractor: Karin Komerac MD,  
Veternik, Serbia  
**Field service**  
PERI Serbia, Šimanovci



▶ Video

## S3 expressway Legnica, Lubawka, Poland

Fast weekly cycle thanks to VIL Incremental Launching Facility



**Wojciech Putowski**  
Bridge Construction Manager

“The VARIOKIT VIL Incremental Launching Facility is particularly quick and easy to operate, leaving the workers more time for other jobs on the construction site. The shuttering itself is also particularly fast – we were able to move the 25-m-long formwork into position within 30 minutes. We are very satisfied with the system and we have also been able to rely on PERI’s support at any time.”

**Contractor**

Konsorcjum Mosty Łódź Inc. & ONDE Inc., Łódź, Poland

**Field service**

PERI Poland, Płochocin

**PERI assisted with the construction of the 480-km-long S3 expressway in western Poland. For the erection of the three bridges in the section between Legnica and Lubawka, a comprehensive PERI solution involving the VARIOKIT Incremental Launching Facility was the key to success. This proved successful due to its reduced material quantities and time-saving handling characteristics.**

A special feature of the VARIOKIT Formwork Units for the external formwork was the striking mechanism: When the casting bed was lowered, the mechanism pushed the external formwork outwards in a horizontal direction. This provided the necessary distance between the cured structure and the struck formwork when moving the superstructure, which is necessary for narrower bridge radii. While the casting bed was being raised, the mechanism then automatically pulled the external formwork back into the concreting position. This meant that no additional alignment of the external formwork was necessary and the site personnel could get started on the next work steps straight away.

The VIL Wall Support with Roller Drophead was used for the slab formwork in the trough to implement the movable slab formwork solution with additional quick striking mechanism. The shuttering method of the VIL System allowed the slab formwork to be moved independently into the concreting position by pulling. The 25-m-long slab formwork was thus pulled into the new cycle and aligned within half an hour. This simplified the workflow and contributed significantly to the project team’s ability to stick to the weekly cycle.

In addition, numerous solutions from the PERI UP Scaffolding Kit were used on the construction site. Among other things, the components provided a high degree of working safety as stair towers, reinforcement scaffolds and working platforms, leading to a successful result through reliable perimeter protection and safe access for site personnel.

Throughout the entire project, PERI engineers were available on site as contact persons to train the construction site team on how to use the VARIOKIT Incremental Launching Facility.





## Theunisbrug, Merksem, Belgium

Parallel bridge construction made possible by reliable availability of materials

**To improve the traffic situation in Antwerp, Belgium, and to modernise the existing infrastructure, the Gabriel Theunis Bridge was raised and the Albert Canal was widened in some places. PERI supported the large-scale project with a system combination.**

One of the most important success factors in large-scale projects of this scale is time. The efficiency of the formwork solution was therefore just as important as the fact that the delivered material enabled simultaneous construction of two bridges. Both were achieved with the PERI solution.

The construction process for the three bridges was similar and essentially only differed in the height at which the system combination of the VARIOKIT Bridge System and VARIO GT 24 Girder Wall Formwork was used. The formwork solution was placed on the bank

before the bridge deck was floated in on the canal. Since the VARIOKIT system parts are available in different standard lengths, individual parts did not have to be specially cut to size.

This saved time and material costs on the construction site. In addition, the formwork performed impressively with its simple and intuitive handling characteristics during the shuttering and striking processes. Concreting was carried out only once on the water; the PERI systems were transported back to the bank with the help of a pontoon after striking.

Due to the fact that both bridges were formed simultaneously, the material requirements were enormous. Close cooperation between several PERI subsidiaries in Europe ensured that all parts arrived on site on schedule, and thus saved an enormous amount of time.



**Maarten Goossens**  
Project Manager Artes Roegiers

“Complex concrete elements had to be created for this project. The 10 m high piers and the bridge deck are good examples of this. We relied on PERI’s expertise for these formwork projects. The good cooperation with PERI contributes to a great result on the construction site.”

**Contractor**  
BELTEK BV, Sint-Niklaas, Belgium  
**Field service**  
PERI BeNeLux, Boom

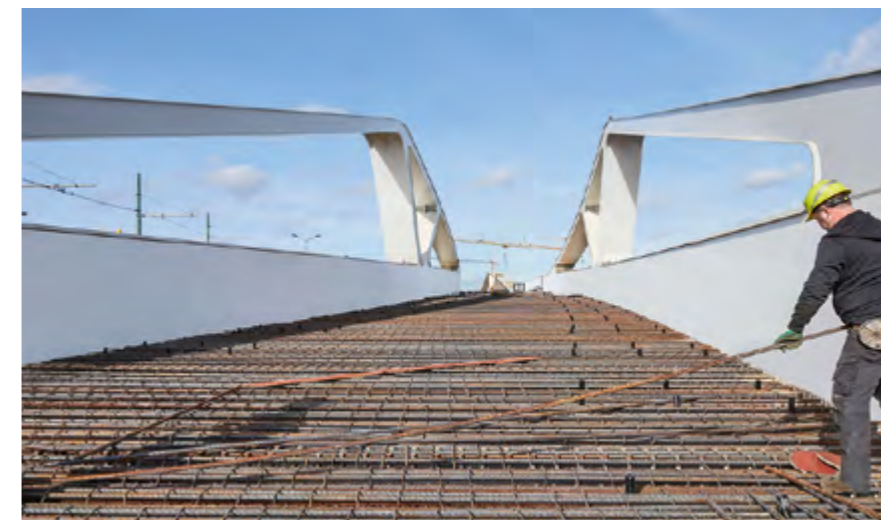

## Ponte de Lucefece, Alandroal, Portugal

On-schedule completion thanks to straightforward assembly process



**Not far from Alandroal, the Lucefece Bridge spans a distance of 664 m at a height of 25 m. As part of the project to modernise the Évora railway line between Freixo and Alandroal, the section will facilitate logistical operations between Portuguese ports and the rest of Europe, but also allow for passenger transport. The project was to be completed in only 10 months. A very challenging deadline, which was met in cooperation with PERI.**

The ALPHAKIT Shoring Construction Kit, which was used extensively during the construction process, impressed on account of its characteristics.

For instance, it could be adapted perfectly to the varying features of the viaduct, which ranges in height from 12 m to 25 m. The system's straightforward assembly process also resulted in fast installation and processing times, thereby significantly reducing the workload. And let's not forget the other advantage of the lightweight steel components: These could be pre-assembled without a crane, thereby minimising the use of cranes on the construction site.

The VARIOKIT Engineering Construction Kit was also decisive for the economic efficiency of the infrastructure project.

The economical use of materials made possible by the structurally optimised components minimised material and labour costs. Furthermore, the combination with the access solutions in the PERI UP Construction Kit facilitated access to the structure, while also ensuring a greater level of safety.

To keep to the tight schedule, a full cycle involving two concreting phases needed to be completed within three weeks. This goal was achieved thanks to the straightforward assembly process of the systems, and the viaduct was completed on schedule – without compromising on work safety.



**Manuel Lopes**  
Site Manager

"By using this innovative, modular falsework, it was possible to adhere to the concreting cycles specified in the construction site plan. It led to a reduction in the movement of materials, and allowed us to systemise the work processes. We achieved a higher level of labour productivity as a result, which enabled us to complete the works on time and to a high standard."

**Contractor**  
Mota-Engil Engenharia e Construção S.A., Lisbon, Portugal  
**Field service**  
PERI Portugal, Castanheira do Ribatejo

## Bridge Road 16, Jerusalem, Israel

### Space-saving formwork for new connection to Jerusalem

**When completed at the end of 2023, Road 16 will cover a distance of around 4.70 km and connect Road 1 in the west of Jerusalem with Road 50 in the east of the megacity. The bulk of the road is to run through tunnels beneath Jerusalem. PERI assisted with the construction of the bridge piers by providing planning services and formwork solutions.**

The infrastructure project posed two major challenges. On the one hand, the uneven, cramped terrain made it impossible to work with shoring towers or formwork carriages; on the other hand, tight budget and time

constraints challenged the engineers from PERI to find particularly time and cost-efficient solutions. To meet the requirements, PERI provided support throughout the project by deploying on-site personnel as well as providing integrated planning services.

For the piers, a system solution consisting of a BR Shaft Platform and CB Climbing Platforms was used, on which VARIO GT 24 Girder Wall Formwork was fixed. In this way, the piers could be formed in a cost-efficient and space-saving manner. The pier heads, in turn, were constructed using a combination of the VARIOKIT and PERI UP

systems. The PERI UP Shoring was fixed to SB Platforms, which were attached to the piers horizontally. This meant that there was no requirement for high shoring towers, which reduced costs.

The superstructure was concreted with VBC. The system is equipped with a comprehensive hydraulic kit to regulate the movement of the formwork from cycle to cycle and to adapt the formwork to the varying cross-sections of the bridge. Concreting was carried out in cycles of 5.30 m on both sides of the piers – both uniformly and simultaneously.



#### Contractor

Shapir Civil and Marine Engineering LTD,  
Petach Tikva, Israel  
Impresa Pizzarotti & C. S.p.A, Parma, Italy

#### Field service

PERI Israel, Rosh Ha'ayin  
PERI Poland, Plochocin  
PERI Group, Weissenhorn



**Alexey Skydin**  
Foreman

“In my view, it was important to work with a reliable formwork company that was able to provide equipment and solutions for the entire bridge: namely the piers and the hammerheads. PERI was the right choice for this reason.”



## Al Bustan Street South, Doha, Qatar

Bridge constructed in record time thanks to engineering solution

**Adherence to deadlines, efficiency and completion without interrupting the flow of traffic: PERI made use of the PD 8 Shoring System and the PERI UP portfolio in addition to a tailor-made VARIOKIT solution with VST Heavy-Duty Towers.**

The Sabah Al Ahmad Corridor infrastructure project is a transport corridor in Doha with a total of four roads and a multitude of multi-lane motorway bridges. The Al Bustan Street South construction project is one of four project phases and features bridges with a total length of more than 10 km. Together with the customer, PERI engineers developed a time-saving engineering solution that was implemented while traffic continued to flow. Around 150,000 m<sup>3</sup> of shoring, 13,000 m<sup>3</sup> of working scaffold, 13,000 m<sup>2</sup> of formwork were used in addition to VST Heavy-Duty Towers. The result is a bridge that consists of an in-situ concrete bridge with 37 piers and a prefabricated concrete bridge with 81 piers.

Combining the modular VARIOKIT and PD 8 systems proved to be the ideal approach for this in-situ concrete bridge. Modifying the systems to accommodate the varying thicknesses of the bridge structure, which ranges from 3.20 m to 4.00 m, was a straightforward process. The prefabricated components of the external web and cantilevered formwork were assembled on the ground, raised by a single crane to save time and then adjusted to marry up with the angle of inclination of the bridge using articulated couplings and a heavy-duty spindle. The PD 8 Shoring System ensured that loads could be transferred in an optimum manner.



VARIOKIT VST Heavy-Duty Towers were used to erect the main bridge and the bridge access roads. The towers were adjusted steplessly using mobile hydraulics to account for the special geometry of the bridge. This made the formwork process particularly efficient and played a major role in ensuring that the project was completed in April 2021. A PERI UP scaffolding solution ensured a high degree of work safety by providing comprehensive, all-round protection on the internal and external sides as well as anti-slip decks. The considerable application potential of PERI UP was utilised in full, namely in the form of reinforcement scaffolds, working platforms, stair towers, access points for finishing works and suspended scaffolds.

**Contractor**  
Hyundai E&C, Seoul, South Korea  
**Field service**  
PERI Qatar, Ar-Rayyan



**Kim Hyungwoo**  
Procurement Manager

“The huge concrete viaduct in the Al Bustan Street South project, covering a distance of more than 10 km, was completed in a very short space of time. Thanks to their extensive supply network and excellent technical support, PERI ensured that we did not run into any delays or technical issues during the entire construction period. Everyone involved in the project made a point of saying that PERI’s solution was the most efficient and reliable they had ever used.”



## Luton DART, Luton, United Kingdom

Short cycle times despite curved geometry



**From 2022, the new Luton DART service (Direct Air-Rail Transit) will ferry passengers between the airport terminal and Luton Airport Parkway station at high speed, on a 24/7 basis, and without the need for a driver. PERI assisted with the £200 million construction project by erecting piers for the viaduct as well as building a 320 m long double tunnel with a curved geometry.**

The viaduct consists of a total of seven piers, two of which were designed as double piers with complex inner arches. For this, engineers from PERI designed a customised formwork solution using VARIOKIT as a basis. Because of the unique soil conditions, conventional systems proved to be impractical. The engineers proposed an alternative solution whereby SB Brace Frames were rotated through 90 degrees and acted as props for platforms, which were also used to carry loads. While they are usually used in single-side forming operations, in this case the frames were placed horizontally around the pier shaft to support the formwork and structure during the curing process. A PERI UP access solution enabled the workers to safely ascend and descend the construction, which reached heights of up to 13 metres.

GT 24 Girders were used in combination with plywood boards in order to construct the tunnel roof. This construction was fixed on MULTIPROP Shoring Towers that were equipped with rollers. This meant that they could be moved on to the next section after the shuttering process without having to be disassembled. As a result, with a cycle time of only one week, a considerable amount of time was saved. Single-sided VARIO formwork elements were connected to intermediate fillers to create a faceted structure that ultimately formed the curve for the tunnel.

**Contractor**  
NJ Doyne, Berkshire, England  
**Field service**  
PERI UK, Brentwood  
PERI UK, Rugby



**Richard Fahey**  
Contract Manager

"The interesting thing about the tunnel is that its curved shape was achieved by reusing straight formwork units. The mobile solution for the pier table system worked brilliantly and reduced turnaround times – especially within confined spaces."

## Cebu-Cordova Link Expressway, South Road Properties, Philippines

Versatility of PERI UP ensures efficient bridge construction

**The Cebu-Cordova Link Expressway is a toll road with a total length of 8.50 km and a width of 27 m. Once completed, around 50,000 vehicles will cross the four-lane bridge between the municipality of Cordova and the mainland of Cebu City on a daily basis. The project required a high degree of cost efficiency while maintaining a high level of occupational safety.**

Components from the PERI UP Scaffolding Kit offered consistent safety throughout the entire works. They were used as access or shoring solutions, for example as stairways

at great heights or across bridge edges for access to important goods lifts. The standardised system decks in a 25-cm-grid also allowed for flexible adaptation to a wide variety of geometries during the project. Another benefit of the PERI solution: A high level of occupational safety due to non-slip decks and comfortable step widths.

PERI also provided support for the project with the planning and supply of formwork solutions, among others for the access viaduct on the Cordova side. From adaptable VARIO Column and Wall Formwork in various sizes to a head trestle solution with horizontal

SB Brace Frames, CB Platforms and a customised heavy-duty console bracket solution, the PERI systems proved their versatility on the construction site and were also safe and efficient in use.

During the entire construction project, PERI engineers were at the customer's side to find optimal approaches to new requirements or to provide support during the implementation of these approaches.



**Contractor**

Cebu Link Joint Venture, Cebu City, Philippines

**Field service**

PERI Philippines, Muntinlupa



**Benjamin Dublin**  
Project Manager

“Thanks to the extreme flexibility of the PERI UP Scaffolding Kit and its high stability, we were able to use it at various points on the bridge, for instance for access to the pile caps, for access to the elevated head sections and for supporting our launched traveller. PERI provided excellent technical support by offering alternative and practical solutions. This helped us achieve high efficiency at the construction site. The close cooperation with PERI also ensured smooth and straightforward implementation on site.”

## San Giorgio Bridge, Genoa, Italy

Pre-assembled VARIO GT 24 and RCS systems for swift cycle sequences

**To construct a bridge to replace the Morandi Bridge in Genoa, which collapsed in 2018, a time-saving solution was required to restore Italy's vital transport link. For the new San Giorgio Bridge, PERI provided an efficient formwork and scaffolding solution that facilitated rapid cycle sequences of two to three days.**

A total of 21 piers in impressive architectural concrete quality support the new bridge at a height of 42 m and a length of 1,067 m over the Polcevera River. For the erection of the piers, PERI's solution included a combination of VARIO GT 24 Girder Wall Formwork with the rail-guided RCS Climbing System which ensured rapid construction progress. The total of five VARIO GT 24 formwork units were tailored precisely to the piers, manufactured with the utmost accuracy in Cremona, Italy and then delivered pre-assembled to the construction site. As the RCS Rails were firmly anchored to the already shuttered building at all times, the solution provided the site crew with reliable protection from the effects of the weather.

TRIO Panel Formwork and PROKIT Guardrails were used for the erection of the foundations. The system combination ensured rapid construction progress thanks to its swift assembly characteristics and also improved safety levels thanks to the all-round protection at the building edges.

In addition, the PERI UP Scaffolding System provided safe access to the formwork at great heights. The assembly process was carried out safely and without any exposed building edges using the guardrail in advance. The metric grid of the components meant that all scaffolding surfaces were closed without any gaps and trip hazards were avoided, which also improved safety.



**Renzo Rossi**  
Site Manager

"The decision to choose PERI as a partner for a project like this did not come about by chance. The outcome is impressive – as in other major projects undertaken by the Webuild Group, PERI again showed a high level of reliability and professionalism."

**Contractor**  
Webuild S.p.A., Italy, Milan  
**Field service**  
PERI Italy, Agrate Brianza

## Second River Niger Bridge, Asaba/Onitsha, Nigeria

Reduced personnel costs thanks to  
VBC Balanced Cantilever Carriage

Once completed, the 1.60 km Second River Niger Bridge will connect the Nigerian cities of Asaba and Onitsha, helping to decongest traffic on the existing bridge over the Niger. PERI assisted with the construction of this key national project with a sophisticated engineering solution based on the VARIOKIT Engineering Construction Kit, the PERI UP Scaffolding Kit and the VARIO GT 24 Girder Wall Formwork.

The bridge consists of three sections with a total length of 1,590 m. PERI assisted with the construction of the 630 m long main bridge, which consists of three 150 m long spans and two 90-m-long spans and crosses the navigation channel upon completion. The piers were erected with the help of a customised system combination. For this purpose, VARIO GT 24 Panels and SB Brace Frames were used, with whose help the platforms were anchored to the previous construction phase in order to safely carry the high loads. It was possible to use the VARIO GT 24 Formwork Elements again for the respective mirror-image pier, which resulted in time and cost savings. In addition, the PERI UP Scaffolding System with integrated ladders ensured safe and easy access for site personnel and performed impressively with its high stability and load-bearing capacity.

The VARIOKIT VBC Balanced Cantilever Carriage ultimately proved to be the right choice for the formwork of 630 m of bridge deck with three lanes in each direction, and spans of 150 m each. PERI supplied a total of four VBC Balanced Cantilever Carriages which were reused for the individual sections. This made the shuttering process particularly efficient and considerably reduced the number of personnel required. The cycle time per segment was a maximum of seven days. It was possible to combine PERI UP efficiently with the VBC solution. Thus, uninterrupted access to the formwork solution was constructed for the site personnel, keeping them safe when working above the water.



**Contractor**  
Julius Berger Nigeria PLC, Abuja  
**Field service**  
PERI ISSU, Spain, Algete  
PERI Nigeria, Lagos



**Stefan Uelzmann**  
Project Manager

"We have a strong and reliable working relationship with PERI. In this project, too, we worked together to solve challenges competently and save costs."

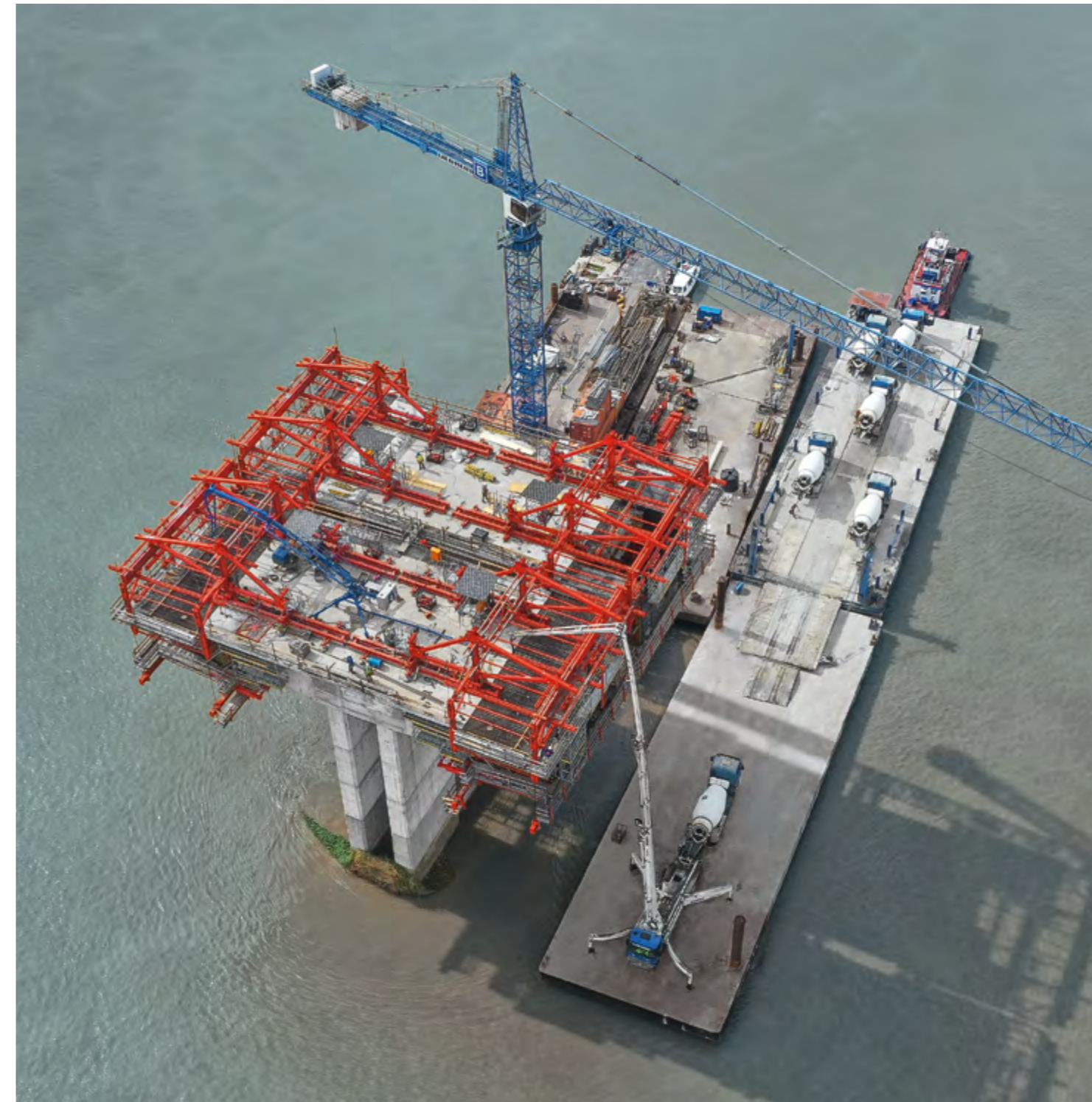

## Tekkale Viaduct, Artvin, Turkey

Combination of VARIOKIT and PERI UP saves time and increases safety

**The Tekkale Viaduct is part of the Yusufeli Dam Project, which is one of the highest dams in the world with its 69 kilometres of roads, 17 tunnels, 4 bridges and a height of 270 metres. Each of the bridges has four lanes, which provide sufficient space for traffic. The total length of the bridges is 2,200 m. The Tekkale Viaduct, which was constructed using PERI systems, has a length of 644 m.**

In order to realise the shape of the piers with variable cross-sections, the decision was made to use the PERI RCS C Rail Climbing System. Its mobile climbing hydraulics not only

helped to save time but also provided the workers with safe working conditions at all times despite strong winds and a height of 150 m. This is because the climbing unit is firmly connected to the structure at all times through the rail-guided system.

The VARIOKIT Engineering Construction Kit was also used to implement the demanding bridge geometry. With the VARIOKIT VBC Balanced Cantilever Carriage, each slab segment could be produced in an average of 7 days – and all this in compliance with occupational health and safety regulations thanks to the safety equipment integrated in the system. The VBC

Balanced Cantilever Carriage made it possible to press ahead with the production of segments with a length of 5.50 m and a weight of 350 tonnes. For the fabrication of the heavy-duty girders, the load-optimised systems VARIOKIT, the single-sided SB Brace Frame and the VARIO GT 24 Column Formwork were combined.

Last but not least, an integral part of the PERI project solution was to combine VARIOKIT solutions with the PERI UP Modular Scaffolding System. By means of this connection, the site managers erected modular work platforms that always allowed safe access to all work areas.



**Kayserşah Erdem**  
Project Manager

“With the Tekkale Viaduct, we not only had to deal with the elevated structures of the viaduct, but also with strong winds that are typical for the region. All this made it necessary to work with a formwork and scaffolding manufacturer that has a wide range of products – PERI was our first choice here. Immediately after the start of construction, it became clear how astute our decision was: in addition to the systems used and the constant attention to the aspect of work safety, it was also the professional site supervision on the part of PERI that ensured that the project was carried out in the shortest time possible and at the highest level.”

**Contractor**  
Nurol – Gülsan Adi Ortaklığı, Yusufeli, Turkey  
**Field service**  
PERI Turkey, Istanbul



## Frankfurt Airport Construction of Terminal 3, Frankfurt, Germany

Customised formwork carriage cuts construction time by several months



**Christopher Diefenhardt**  
Site Manager

“The construction site personnel were pleasantly surprised by the solution for this complex task. Thanks to the systems supplied by PERI, we were able to finish each concreting section about 2 weeks faster than originally planned.”

**Contractor**  
Max Bögl Group,  
Frankfurt, Germany  
**Field service**  
PERI Germany, Nuremberg



**At the south end of Frankfurt Airport, Terminal 3, with its futuristic design, is currently one of Europe’s largest infrastructure projects. Upon completion of construction in 2024, up to 19 million travellers will be able to arrive and depart from the three new gates each year. Together with Max Bögl, PERI assisted with the construction of the drive-by platform, which will in future provide passengers with direct access to the departure level.**

The 550 m long and 27 m wide drive-by platform is supported by 70 V-shaped columns covering an area of almost 15,300 m<sup>2</sup> and connects the two access and departure ramps to the terminal. PERI engineers designed a customised formwork carriage for this complex construction project using the VARIOKIT Engineering Construction Kit and the PERI UP Scaffolding Kit as a basis. It was 40 m long, 25 m wide and 12 m high – with a total weight of just under 500 tonnes. The construction was carried out entirely in 3D.

With an integrated hydraulics system, the entire formwork carriage could be lowered by 2.20 m for striking and repositioning. Between the V-supports, the solution was made up of six individual carriages that could be separated for relocation and striking. Outside the V-supports there were two further carriage units that were 40 m in length and could be moved in one piece. For the relocation process in the longitudinal and transverse direction, PERI developed a special hydraulic walking gear that could be transported back and forth between the individual carriage units quickly, easily and manually.

The formwork of the oblique-angled and V-shaped beams of the drive-by platform posed a particular challenge. In this case, it was necessary to shutter and strike the beams separately from the formwork carriage – and in a very confined area. This was realised by means of a folding mechanism and the MAXIMO Structure because of the lower construction height compared to the girder formwork. MAXIMO Structure also made it possible to achieve the desired SB2 architectural concrete class. The beam formwork was operated from a PERI UP Platform located in the belly of the formwork carriage. In order to meet all the occupational safety requirements, all access points and working platforms in the formwork carriage were constructed using the PERI UP Scaffolding Kit.

It took more than 16 hours to concrete the first 36 m long concreting section. The formwork carriage, weighing almost 500 t, was ready to be moved to the next concreting section within just one week. A further 13 concreting operations were carried out in order to complete the entire drive-by platform.



## Filstal Bridge, Mühlhausen im Täle, Germany

Solution expertise with modular systems

**Customer-oriented planning and services combined with coordinated modular systems form the basis for developing formwork and scaffolding solutions that are suitable for almost any site requirements, including complex infrastructure projects. PERI engineers assisted with the construction of the Filstal Bridge, bringing their extensive solution expertise to bear.**

The 485-m-long Filstal bridge with its two separate bridge sections is considered the most fascinating structure on the new high-speed Wendlingen-Ulm railway line. At 85-m-high, it is one of the highest railway bridges in Germany.

The Filstal Bridge brings together all conceivable challenges of bridge construction: high bridge piers that widen in a Y-shape at the crown, a sophisticated construction method with slender superstructures, high architectural concrete requirements from Deutsche Bahn and a narrow time window to meet the completion deadline because of interim adjustments to the structural

model of the bridge structure. When constructing the piers, superstructure and tunnel portal, the PERI infrastructure specialists always found a solution that allowed them to meet the completion deadline and at the same time achieve a high quality of workmanship.

The pier shafts sprouted upwards with the help of the rail-guided RCS Climbing System. In the complicated expansion areas at the pier head, work platforms based on the RCS and SCS Climbing Systems ensured that the loads could be transferred safely. PERI UP reinforcement scaffolds installed around the perimeter

provided a safe working environment. A rail-guided finishing carriage based on PERI UP, VARIOKIT and RCS, which could be moved hydraulically in 50-cm-increments to the required position, was used for working on the inclined piers between the Y-pier head and the superstructure.

While a total of four VARIOKIT Cantilever Parapet Carriages were used to construct the cantilevered parapets on the west bridge, the work platforms were kept available along the entire length of the bridge so that the parapets could be constructed in sections on the eastern superstructure.

The platforms were also fitted with PERI UP scaffold suspensions and extensions for additional use as assembly and finishing platforms. The comprehensive service package provided by PERI comprising engineering services, construction site support, chief erectors and factory pre-assembly even included the final construction of the tunnel portals as a transition between the bridge and the tunnel using a tailor-made VARIOKIT Tunnel Formwork Carriage.



### Contractor

Consortium EÜ Filstal:  
Max Bögl and  
PORR GmbH & Co. KGaA, Munich

### Field Service

PERI Germany,  
Competence Center Infrastructure,  
Weissenhorn/Cottbus  
and Nuremberg branch office



**Willy Brückner Foreman**  
**Norbert Klopff Foreman**

“When we needed the guys from PERI, there they were. We were always able to find a solution for everything together. Planning and delivery always took place on time.”



## Neckar Bridge, Benningen, Germany

An elegant sweep across the River Neckar in record time



The impenetrable decking of the VGK Cantilevered Parapet Bracket solution provided sufficient protection for crossing vessels, and the separate formwork unit could be continuously adjusted to accommodate the required parapet geometry.

The new, elegantly curved bridge over the River Neckar is a steel composite bridge with narrow steel waling and a wide cantilevered concrete superstructure.

**Engineering structures along transport routes negotiate obstacles and are often harmoniously integrated into the landscape or urban area using suitable architectural design. With modern construction methods, a wide range of supporting structures can be realised – within the planned time frame and, in particular, with due consideration for economic efficiency, safety and durability standards.**

The 195-m-long bridge, in conjunction with a 107-m-long retaining wall, forms the basis for the new 1.2-km-long L 1138 bypass between Freiberg and Marbach.

The new Neckar bridge has been designed and executed as a steel composite structure with a hollow box. The steel waling merges seamlessly and monolithically into the V-shaped river piers. The design using a haunched frame bridge fits harmoniously into a landscape that is characterised by vineyard slopes and also facilitates a slender construction with a construction height in the midspan above the River Neckar of only 1.90 m. This is because a 60.00-m-wide and 6.30-m-high clearance for inland navigation had to be maintained in the area of the 86 m support span of the central river area. The architecturally and structurally demanding bridge construction was

also challenging in terms of the construction work: The very narrow hollow steel sections, only 4 m wide, were tightly welded and partly pre-assembled on the banks of the River Neckar, and the 145 t centre section was lifted into its final position using a floating crane. Due to the bridge's geometry, which is curved in two axes, the concrete superstructure also posed corresponding challenges: The bridge transitions from a turning clothoid to a radius of 125 m and is inclined by up to 7.5 % in the longitudinal and transverse direction. And, when carrying out construction work above water, everything had to be operated from above in the area around the River Neckar.



**Hüseyin Aktas**  
Site Manager

“For this construction site, VARIOKIT was the optimal system with its ease of use and fast turnaround times. We concreted up to 20 m of bridge every week, and in only 12 weeks the 195-m-long bridge superstructure was finished in record time. The site supervision by PERI was also top-notch: The technical competence, the fast response time and excellent cooperation provided the basis for an extremely good construction process.”

The practice-oriented VARIOKIT modular system from PERI aims to provide cost-effective solutions for the majority of civil engineering requirements. During the process, the focus is on providing a high proportion of rentable core and system components that cover the extensive range of applications featured in tunneling, bridges and general civil engineering. A customised modular solution was developed for this specific project. During the first phase, the suspended VARIOKIT cantilevered formwork made it possible to construct the bridge superstructure, which was divided into 11 sections, each 15-20 m long, in regular weekly cycles. The subsequent installation of the bridge parapets was carried out with the help of the VARIOKIT cantilevered parapet bracket.



Construction of the 195-m-long bridge superstructure and the cantilevered parapets was carried out using the VARIOKIT Engineering Construction Kit as a basis and with the PERI support team providing on-site assistance.

**Contractor**  
WOLFF & MÜLLER Ingenieurbau GmbH,  
Bridge Construction Branch, Stuttgart  
**Field Service**  
PERI Stuttgart branch office and PERI Infrastructure  
Competence Center, Weissenhorn

The VARIOKIT VCB Cantilever Bracket was used to construct the up to 45-cm-thick concrete carriageway slab of the bridge structure, which was built using the steel composite construction method. Despite the enormous 3.95 m cantilever on both sides, the team was able to work with a generous bracket spacing of 90 cm. Another significant advantage was that the VARIOKIT system solution could be adapted to the respective construction situation in a fan-shaped manner using two different suspension variants: In the areas above land, the suspension could be released from below after the concreting and curing processes. For the concreting sections above water, the suspension was designed in such a way that the platforms could be detached from

above and relocated by crane. In both cases, the superstructure was freely accessible. The prestressing steel suspension, which sat flush with the upper edge of the concrete, prevented interference points and facilitated high concreting speeds through the use of vibrating beams.

The easy-to-handle VARIOKIT VGK Cantilevered Parapet Bracket was the most economical construction solution for the bridge parapets of the Neckar bridge with a length of almost 200 m and also facilitated safe and efficient work processes. By anchoring the platform units to the underside of the bridge, all work on the top side of the superstructure could be carried out without disruption.